

SKIPPER EML224

Two-axis Electromagnetic Log Installation And Operating Manual

Edition 20070822sw.1.27.12



Skipper Electronics A/S
Ryensvingen 5
P.O.Box 151, Manglerud
0612 Oslo, Norway
www.skipper.no

Telephone +47 23 30 22 70
Telefax +47 23 30 22 71
E-mail: skipper@skipper.no
Co.reg.no: NO-965378847 -MVA

SKIPPER

Weitergabe sowie Vervielfältigung dieser Unterlage, Verwertung und Mitteilung ihres Inhaltes nicht gestattet, soweit nicht ausdrücklich zugestanden. Zuwiderhandlungen verpflichten zu Schadenersatz.

Toute communication ou reproduction de ce document, toute Exploitation ou communication de ou son contenu sont interdites, sauf Autorisation expresse. Tout manquement à cette règle est illicite et Expose son auteur au versement de dommages et intérêts.

Copying of this document, and giving it to others and the use or Communication of contents thereof, are forbidden without express Authority. Offenders are liable to the payment of damages.

Sin nuestra expresa autorización, queda terminantemente prohibida la Reproducción total o parcial de este documento, así como su uso Indebido y/o su exhibición o comunicación a terceros. De los infractores Se exigirá el correspondiente resarcimiento de daños y perjuicios.

CONTENTS

1. INTRODUCTION	5
SYSTEM SUMMARY.....	5
SENSOR.....	5
OPERATOR UNIT.	5
Data Entry.....	5
Fig. 1.1 System Overview.....	6
INTERFACING.....	7
Outputs.....	7
Inputs.....	7
ALARMS.....	7
2. OPERATION.....	8
PARAMETER ENTRY	8
Fig. 2.1 Setting and Parameter Entry Flowchart	8
OPERATION SCREENS	9
Fig. 2.2 Schematic overview of screens and softkey menus	9
Fig. 2.3 Screen A	10
Fig. 2.4 Screen B	11
Fig. 2.5 Screen Com Menu 1.....	12
Fig. 2.6 Screen Com Menu 2.....	13
Fig. 2.7 Screen Status, Menu 1	14
Fig. 2.8 Screen Status, Menu 2	15
Fig. 2.9 Screen Status, Menu 3	16
Fig. 2.10 Screen Status, Menu 4	17
Fig. 2.11 Screen Status, Menu 5	18
Fig. 2.12 Screen Status, Menu 6	19
Fig. 2.12 Screen Calibration, Menu 1	20
Fig. 2.13 Screen Calibration, Menu 2	21
Fig. 2.14 Screen Calibration, Menu 3	22
PRINCIPAL FUNCTIONS	23
Principles of Electromagnetic Log.....	23
Power ON/OFF	23
Alarm acknowledgement.....	23
FIXED KEY FUNCTIONS.....	24
Screen Select	24
Backlight adjustment	24
KEY FUNCTIONS.....	25
Menu.....	25
Trip Reset	25
Alarm settings.....	25
Clock and Calendar Settings	25
Simulator.....	25
Status Screen.....	25
Non-volatile Parameter Memory.....	25
OPTIONS.....	25
Repeaters/Slaves	25
3. USER MAINTENANCE	26
TRANSDUCER MAINTENANCE.....	26
OPERATOR UNIT MAINTENANCE.....	26
4. INSTALLATION	27
STANDARD SYSTEM SUPPLY.....	27

HULL FITTING.....	27
Fig. 4.1 Hull Fitting service clearances.....	27
TRANSDUCER LOCATION.....	28
PART POSITIONING AND WELDING.	28
REQUIRED ELECTRODES.....	28
WELDING PRECAUTIONS.	28
TRANSDUCER INSTALLATION.	28
THE JUNCTION BOX.	28
TRANSDUCER/JUNCTION BOX INTERCONNECTION.	29
Fig. 4.2 Sensor Junction box, Location of Fuses and LEDs.....	30
TRANSDUCER/JUNCTION BOX	30
OPERATOR UNIT INSTALLATION.	31
Fig. 4.3 Voltage selection connectors and fuses, Terminal Board.	32
Fig. 4.4 History Memory Battery Jumper, I/O Board.	33
BACK-UP BATTERY JUMPER 200.....	33
Fig. 4.5 Function LED's, Terminal and CPU Boards.	34
INTERFACING.	35
Fig. 4.6 Input/Output Circuitry.....	35
ALARM RELAY	36
LOG PULSE OUTPUTS.....	36
ANALOGUE INTERFACES	36
NMEA INTERFACE	36
OPTIONS.	37
Repeaters/Slaves	37
5. START-UP AND SYSTEM ADAPTION.....	38
ANALOGUE OUTPUTS AND LOG PULSE OUTPUTS RANGE SELECTION.....	38
LANGUAGE AND UNITS OF MEASURE	38
NMEA SETUP.....	38
EML224 TRANSMITTED(ORIGINATED) NMEA0183 MESSAGES.....	39
SPEEDLOG CALIBRATION PROCEDURE	40
ACTIVATION OF THE CALIBRATION MODE.....	40
Fig 5.1. Hidden key inside door of Operator unit.....	40
INSTALLATION ANGULAR ERROR CORRECTION.	41
SPEED CALIBRATION TRIP.	41
MANUAL ADJUSTMENT OF CALIBRATION TABLE.	43
6. SPECIFICATIONS.....	44
FUNCTIONAL PROPERTIES	44
PERFORMANCE.....	45
7. TROUBLE SHOOTING	46
BASIC SYSTEM INTEGRITY	46
INSTALLATION PROBLEMS	47
INTERFACE PROBLEMS.....	47
BASIC FUNCTIONALITY	47
TYPICAL STATUS SCREEN CONTENTS.....	48
Fig. 7.1 Typical contents of status screen	48
8. SERVICE.....	49
9.APPENDIX.....	50
MISCELLANEOUS INSTALLATION DRAWINGS.	50

1. INTRODUCTION

SYSTEM SUMMARY.

The EML224 is a navigation, two-axis electromagnetic log with a large, high resolution graphic colour LCD. This LCD has the possibility of displaying a number of variables in both numerical and graphic forms. The information from the electromagnetic sensor includes longitudinal and transversal speeds, drift angle and sea temperature. It is thus possible to get a very good picture of the vessels total movements.

An electromagnetic log will of course give direction of speed in both axes (Ahead/Astern, Starboard/Port). This is of great importance during manoeuvring or when running at low speeds. The speed range is the same Astern and Ahead. The user may optionally select display text languages as well as various units of measure.

All IMO requirements are met or exceeded. Comprehensive interfaces are available including NMEA0183 input and output.

SENSOR.

The sensor is an active electromagnetic unit that can be fitted into various tank or valve solutions. The sensor is virtually maintenance free, but occasional cleaning may be necessary depending on sea water conditions. Ordinary fouling will be limited, due to the electromagnetic field surrounding the sensor. The sensor has no moving parts and protrudes only a few millimetres outside the hull.

The sensor is interfaced through a junction box which also contains the power supply. This junction box is mounted near the hull fitting, and two pairs of cable are led to the display unit for digital signal transmission. The power consumption of the Junction Box is Max. 35W. Voltage 115/230V AC or 24V DC.

OPERATOR UNIT.

The operator unit contains a colour TFT LCD display and a keyboard with fixed keys, soft-keys and a rotating encoder. The function of each softkey button depends on the active screen, and the buttons are labelled on the lower rim of the LCD. The display is backlit and backlight intensity may be adjusted by the user for both day and night vision. Various user-selectable information layouts, adapted to typical operational situations, may be displayed continuously on the LCD screen. The operator unit is normally flush mounted.

Operator Unit power supply options are 230/115V AC or 24V DC. The power consumption is max. 70 Watts at 115/230V AC or 50 Watts at 24V DC.

Data Entry.

Several screens may be selected to enter various settings and calibration parameters. Each screen has one or more softkey button menus, selectable with the leftmost "Menu" Softkey.

Screens A and B are primary operation screens with appropriate operator controls. Screens COM, STATUS and Calibration are setup and system supervision screens.

The various screens will be described in detail later.

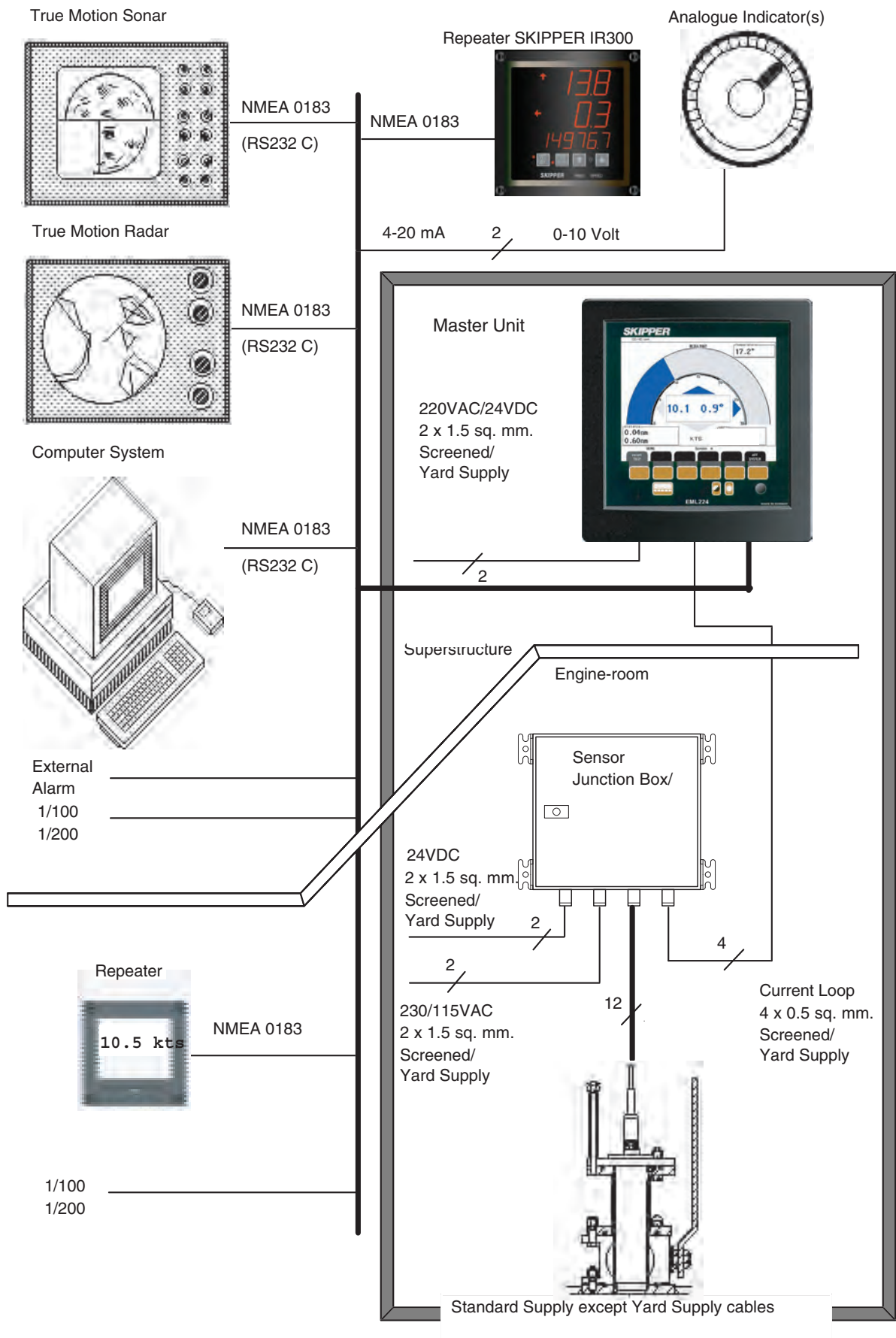

Fig. 1.1 System Overview

INTERFACING.

The EML224 has various interface possibilities.

Outputs.

3 Log Outputs 100/200/400/1000 Pulses per nautical mile.

3 Analogue Outputs 0-10 V or 4-20 mA.

NMEA0183 Interface Output of Speed Information.

External Alarm Relay Output.

Inputs.

NMEA0183 Interface Input and Position, Heading, Depth, UTC.

Remote Alarm reset.

ALARMS.

High and low speed alarms may be selected from the menus. A potential free relay contact is provided in EML224 for interface to external alarm systems.

Input for remote alarm reset is available.

2. OPERATION

When the installation is complete, and power is connected to the Operator Unit, the system is switched on by pressing any button. The unit is switched off by pressing the “SYSTEM off” soft key button on Screen A and Screen B.

PARAMETER ENTRY

The fixed function buttons and the soft key buttons on the various screens along with the rotating encoder, facilitates entry of parameters, setpoints and other data. The following flow chart illustrates the procedure for changing settings and entering data. The various screens are shown in detail in the Operation Section.

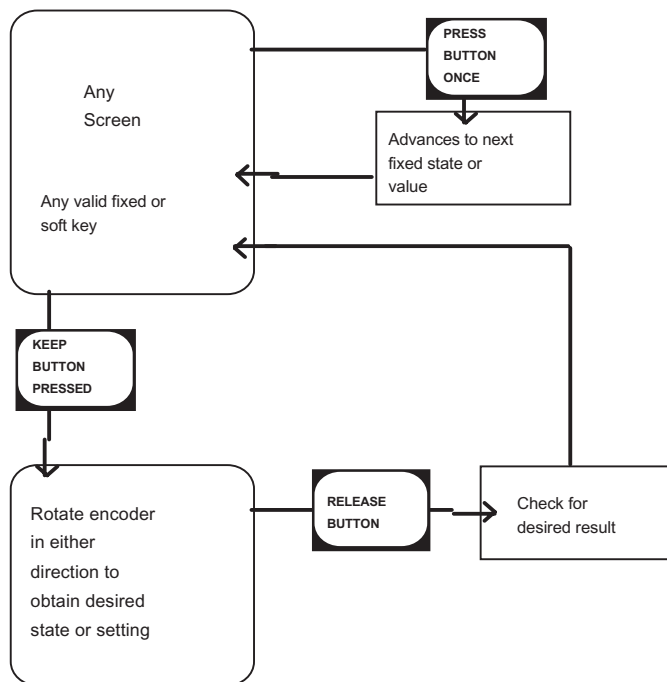

Fig. 2.1 Setting and Parameter Entry Flowchart

Example of parameter entry.

Let us say you want to enter a value of **15 kts.** for the High Speed Alarm.

Press a High Speed Alarm Soft Key, e.g. in Screen Status, Menu 1, and keep it pressed while you turn the encoder until you reach 15 kts, let go of the encoder and release the High Speed Alarm button. Buttons with less than 6 possible states or values can be operated without using the encoder at all.

OPERATION SCREENS

Each of the operation screens contains a graphic picture and one or more Menu sets configured on the 6 soft key buttons. The various screens are selected by keeping the SCREEN SELECT button pressed and rotating the encoder in either direction. Turning the encoder clockwise cycle the screens in the sequence 1 to 5, and counter clockwise rotation cycles the screens in the sequence 5-1. Screens A and B, covering the primary functions, may also be cycled by repeatedly pressing the SCREEN SELECT button. Screen COM, STATUS and CALIBRATION is mainly used for Setup and Function Control, and may only be accessed by the rotating encoder.

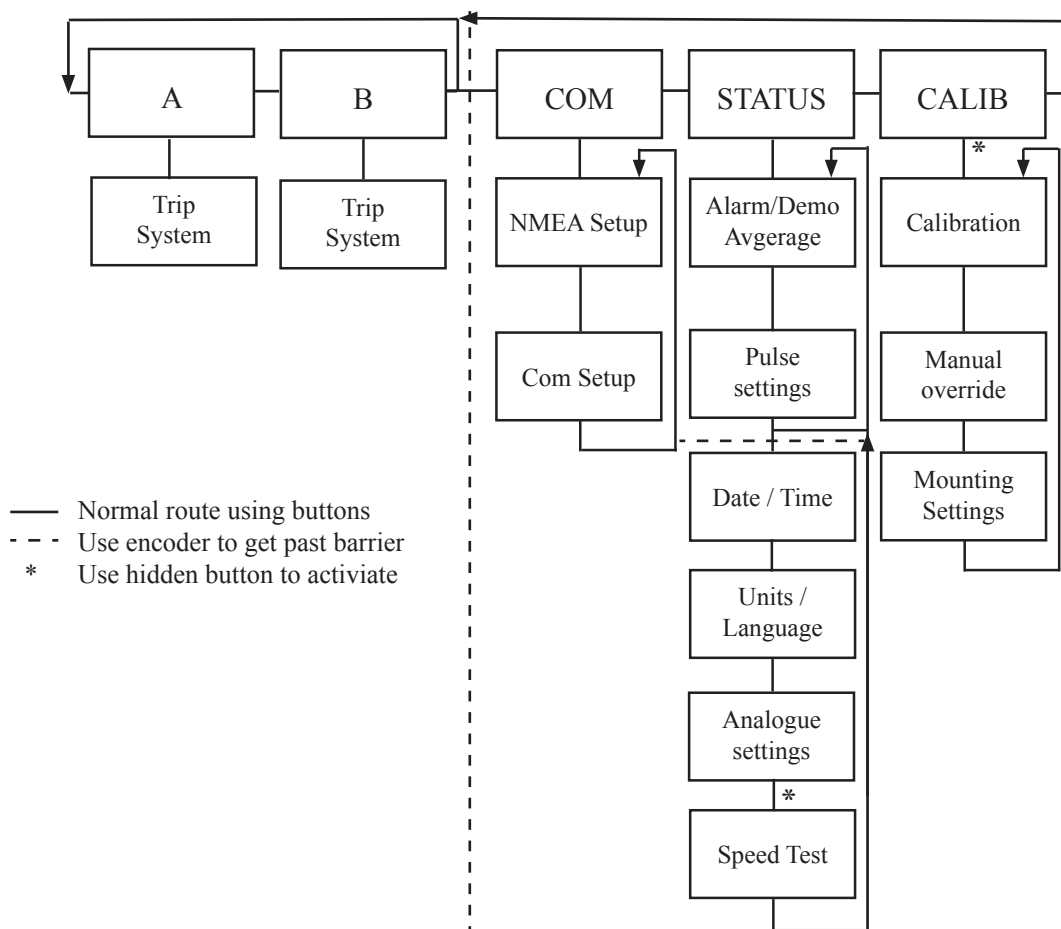

Fig. 2.2 Schematic overview of screens and softkey menus

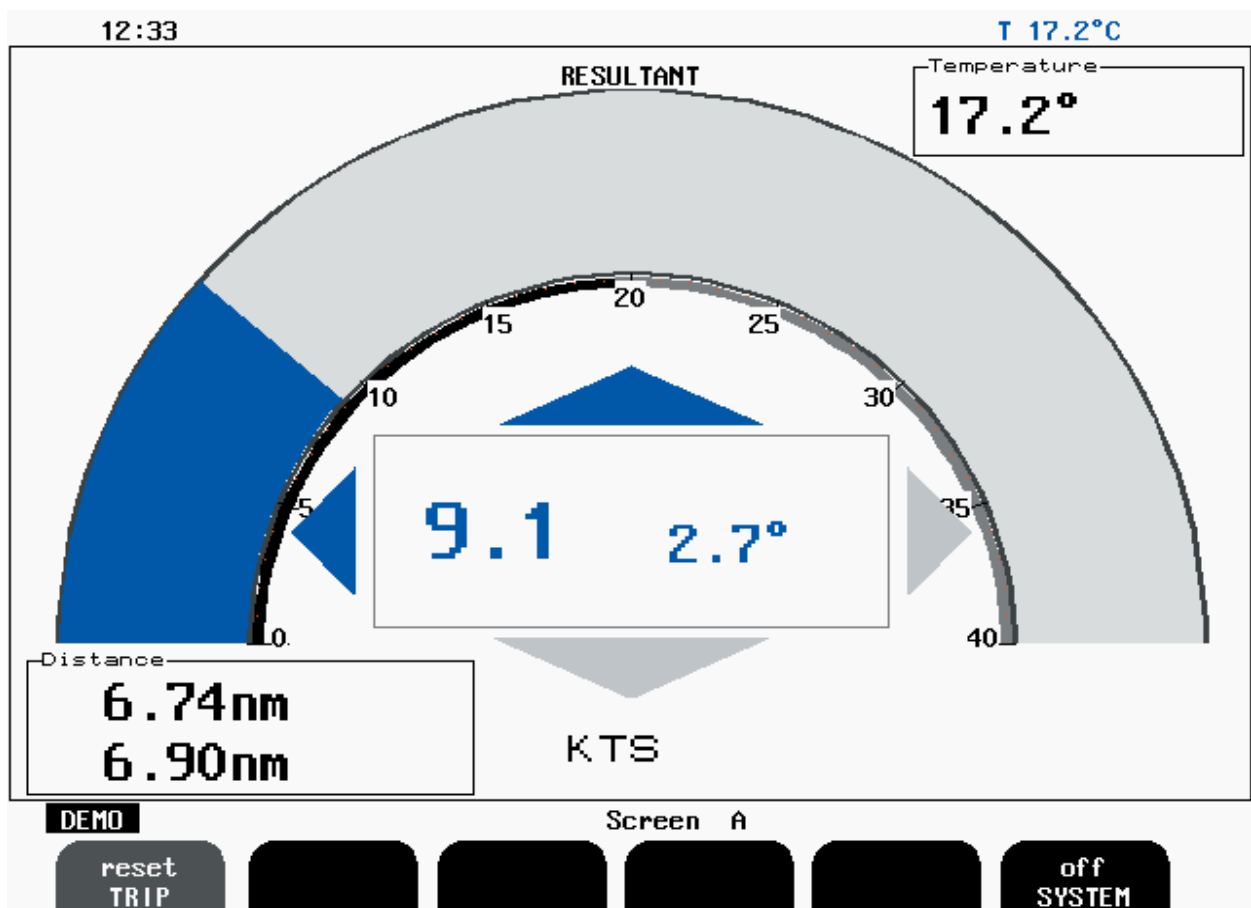

Fig. 2.3 Screen A

Soft key 1: TRIP
 Soft key 2: Not used
 Soft key 3: Not used
 Soft key 4: Not used
 Soft key 5: Not used
 Soft key 6: SYSTEM

Trip Distance Counter Reset

System OFF.

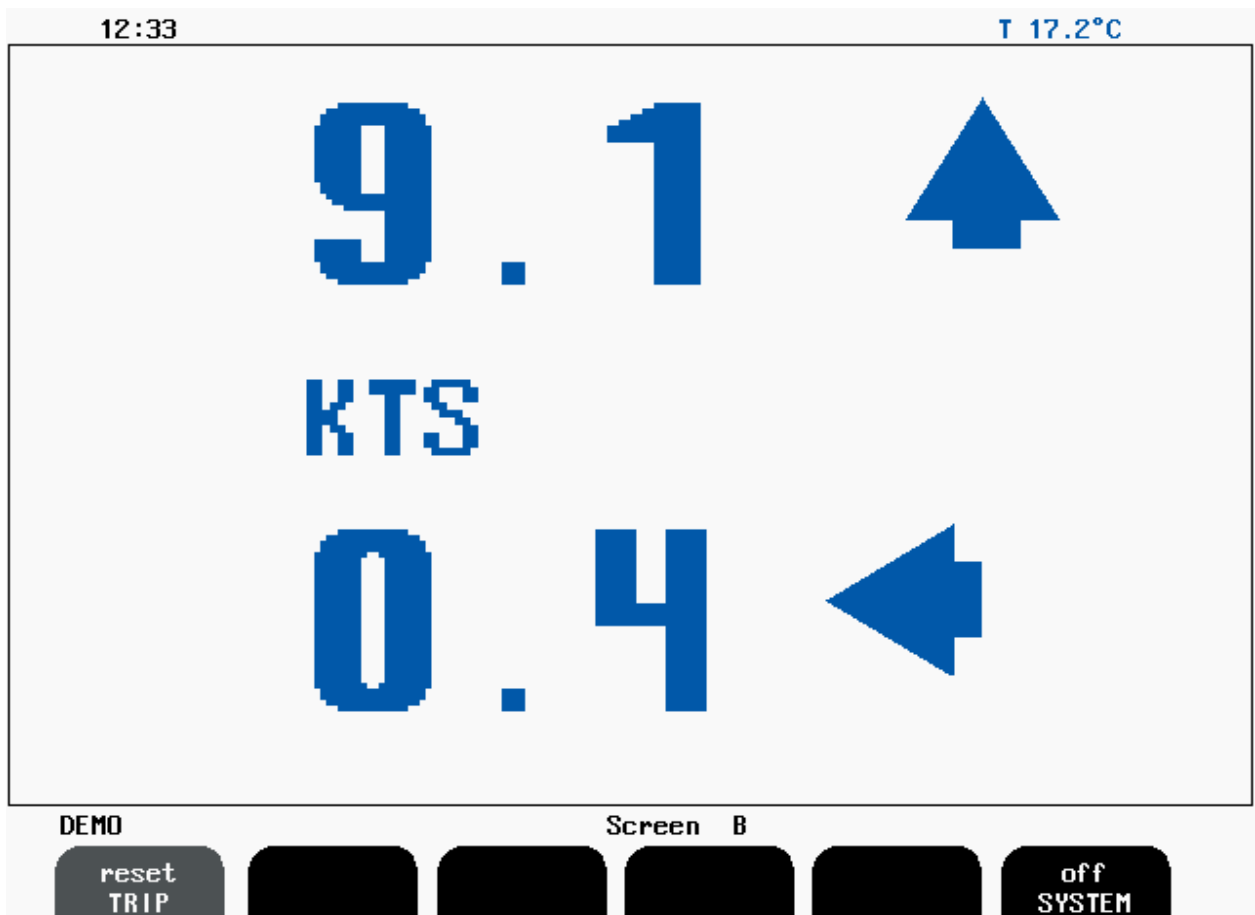

Fig. 2.4 Screen B

Soft key 1: TRIP

Soft key 2: Not used

Soft key 3: Not used

Soft key 4: Not used

Soft key 5: Not used

Soft key 6: SYSTEM

Trip Distance Counter Reset

System OFF.

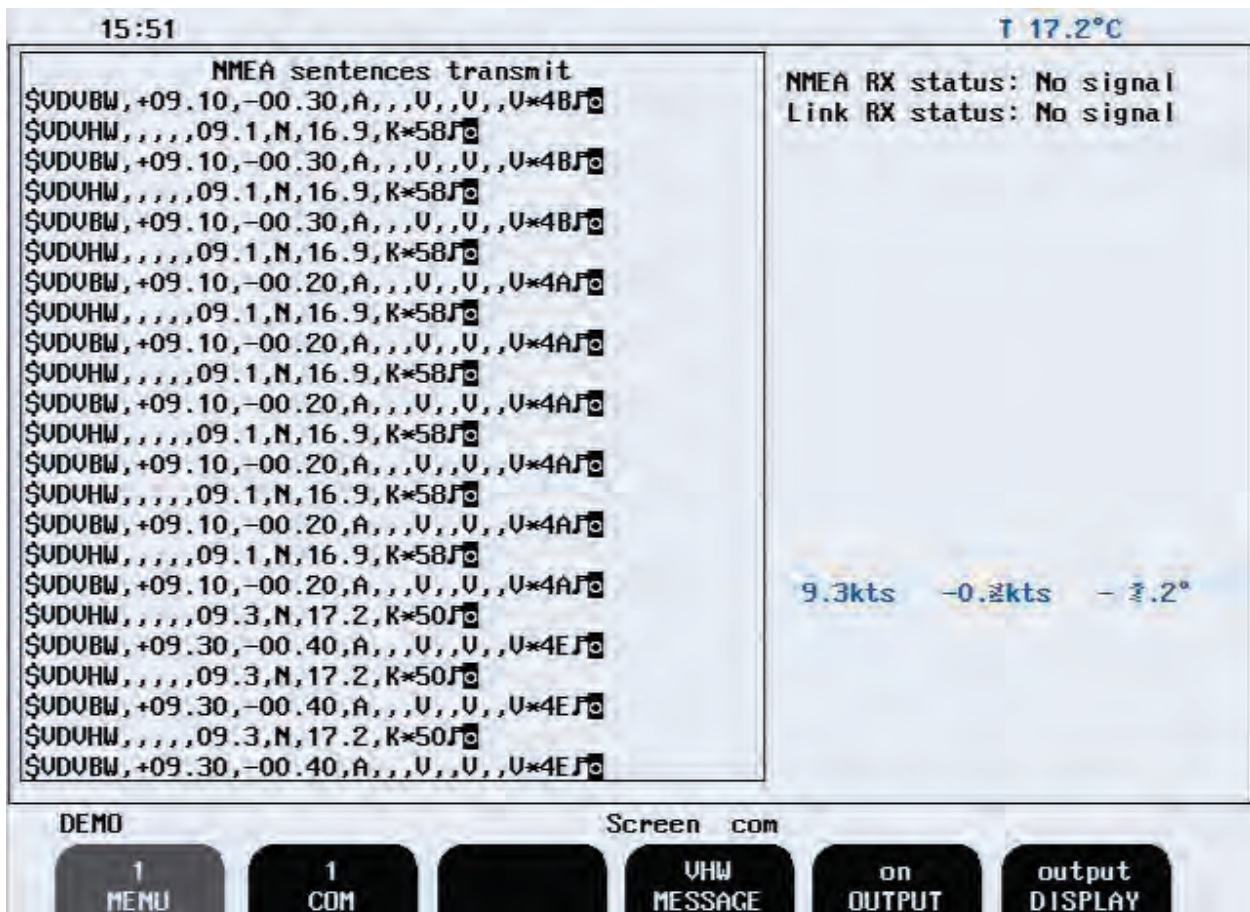

Fig. 2.5 Screen Com Menu 1

Soft key 1: MENU	Chosen menu number 1
Soft key 2: COM	Serial port # referred by other keys.
Soft key 2 :BAUD	Baudrate for Com Port #n [1200, 2400, 4800, 9600, 19200, 38400, 76800, 115200]
Soft key 3: Not used	
Soft key 4: MESSAGE	NMEA message selector. Each message may be controlled individually by Softkey 5 [VHW, VLW, VBW].
Soft key 5: OUTPUT	Setting for the Message in Softkey 4 [On/Off] Note: To configure the serial output of the system, go through all the messages by pressing soft key 4 and set on/off value of the softkey 5 to disable/enable a message as required.
Soft key 6: DISPLAY	Selects the information (received from the external source or transmitted by the EML224) to be displayed in the “TEXT” window. [Input, output, off].

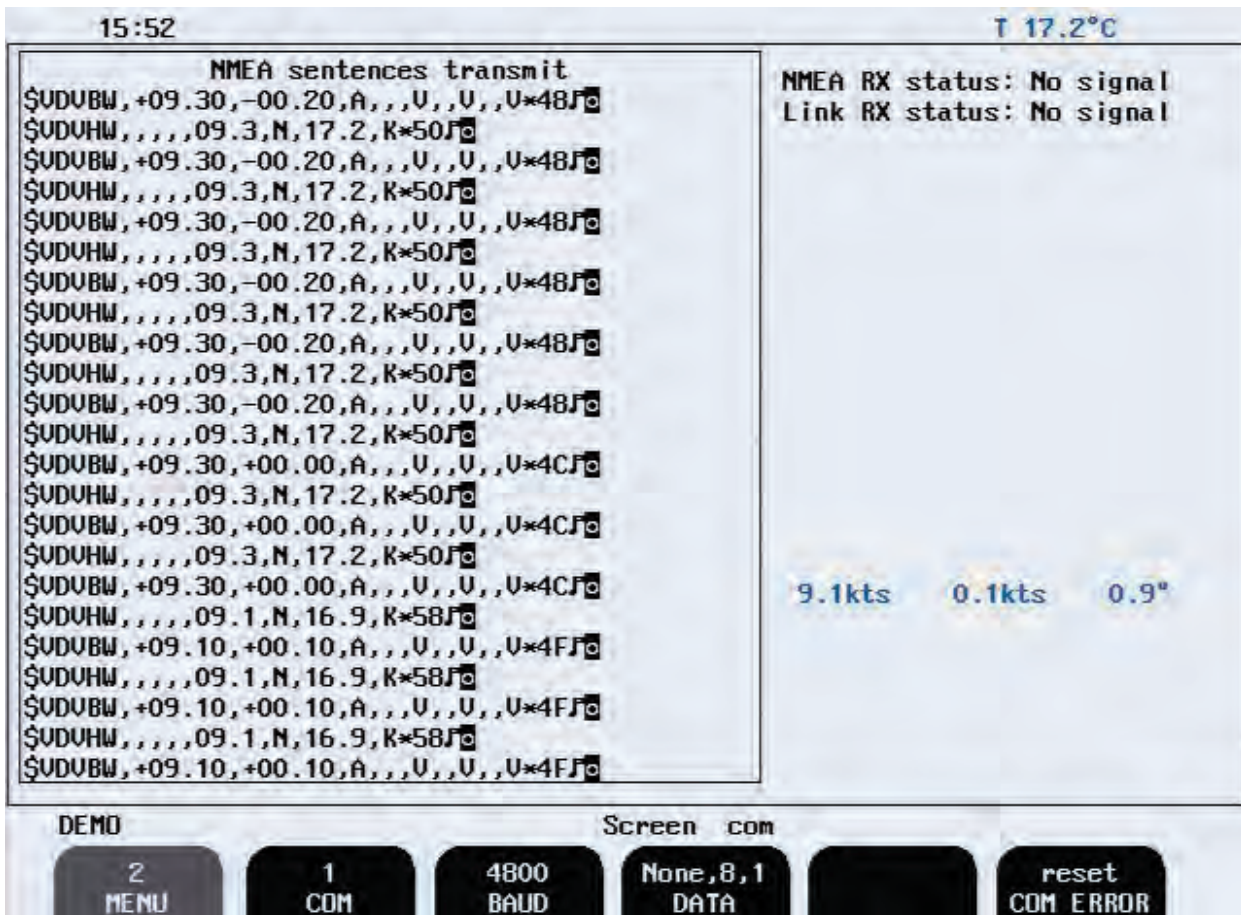

Fig. 2.6 Screen Com Menu 2

Soft key 1: MENU

Soft key 2: COM

Soft key 3: BAUD

Soft key 4: DATA

Soft key 5: Not used

Soft key 6: COM ERROR

Chosen menu number 2

Serial port # referred by other keys.

Baudrate for Com Port #n

[1200, 2400, 9600, 19200, 38400, 76800, 115200]

Data Format for Com Port #n (Parity-Data Bits-Stop Bits)

[None-7-1, Even-7-1, Odd-7-1, None-8-1, Even-8-1,

Odd-8-1, None-7-2, Even-7-2, Odd-7-2, None-8-2,

Even-8-2, Odd-8-2]

The program memorizes the latest occurred NMEA input error for further analysis (error code presented on the Status and Com screens). By means of this soft key it is possible to reset the error.

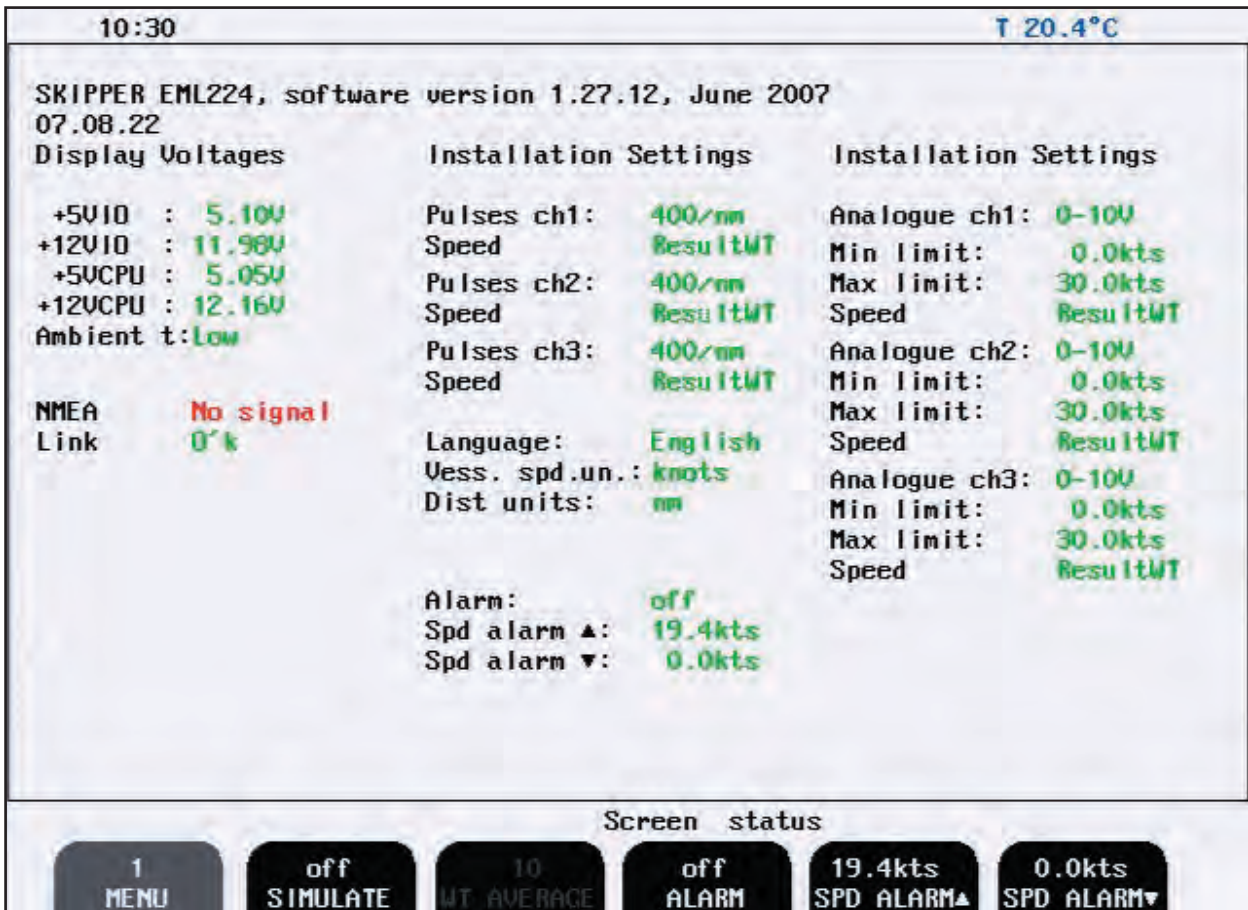

Fig. 2.7 Screen Status, Menu 1

Soft key 1: MENU

Soft key 2: SIMULATE

Soft key 3: WT AVERAGE

Soft key 4: ALARM

Soft key 5: SPD ALARM ▲

Soft key 6: SPD ALARM ▼

Chosen menu number 1

Simulator on/off

Number of individual samples to be averaged in Water Track mode to provide better accuracy.

Alarm on/off

High Speed Alarm

Low Speed Alarm

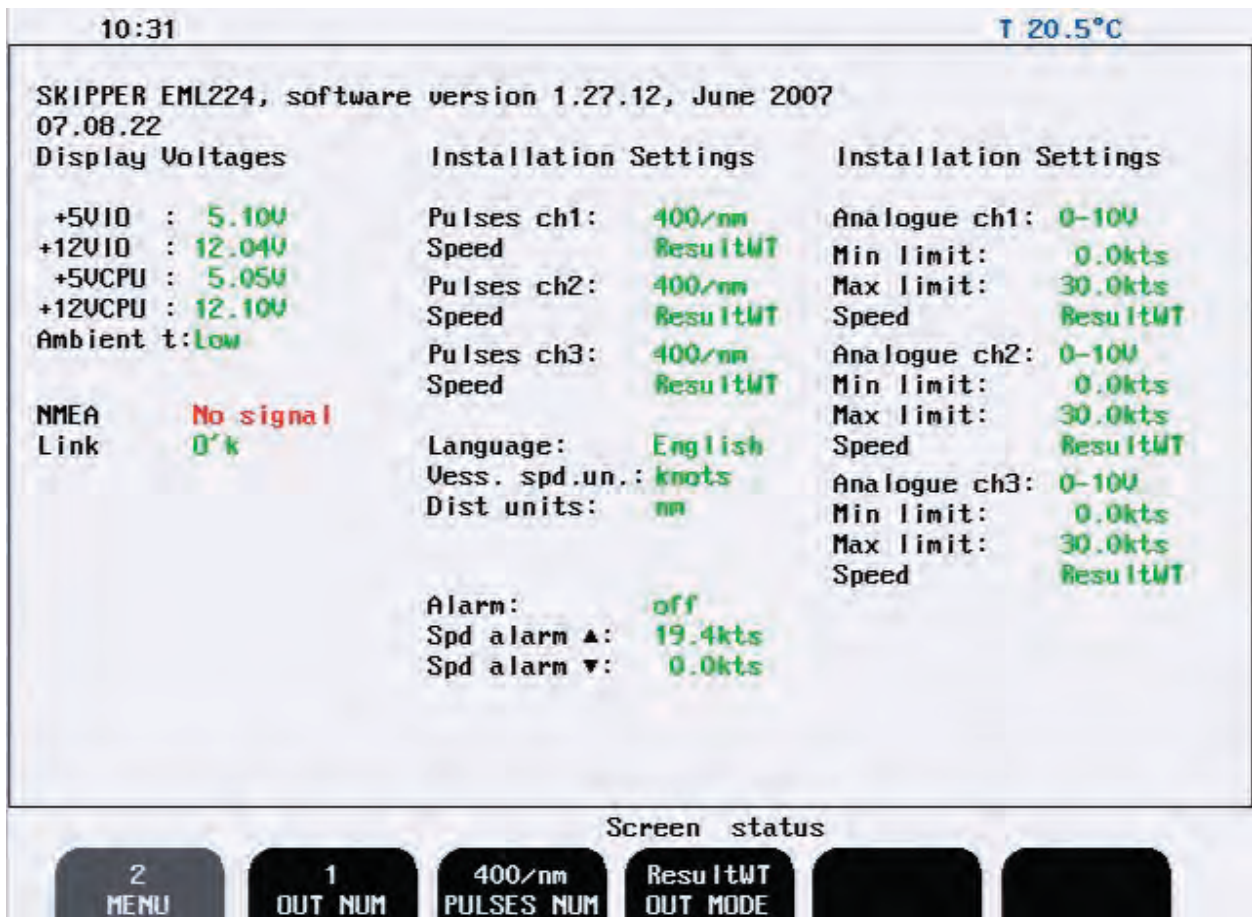

Fig. 2.8 Screen Status, Menu 2

- Soft key 1: MENU Chosen menu number 2
- Soft key 2: OUT NUM Pulse Output Channel to be configured by Keys 3 and 4; [ch1, ch2, ch3]
- Soft key 3: PULSES NUM Number of Pulses per Nautical Mile at this Channel (Key 2):
Channel 1 and 2 are reed-relay outputs, programmable from 10, 100, 200 and 400 p.p.nm.
Channel 3 are optocoupler output, programmable from 10, 100, 200, 400 and 1000 p.p.nm.
- Soft key 4: OUT MODE Speed Parameter to be output at this Channel (Key 2): [ResultWT, ForAftWT, Lateral/WT]
- Soft key 5: Not used
- Soft key 6: Not used

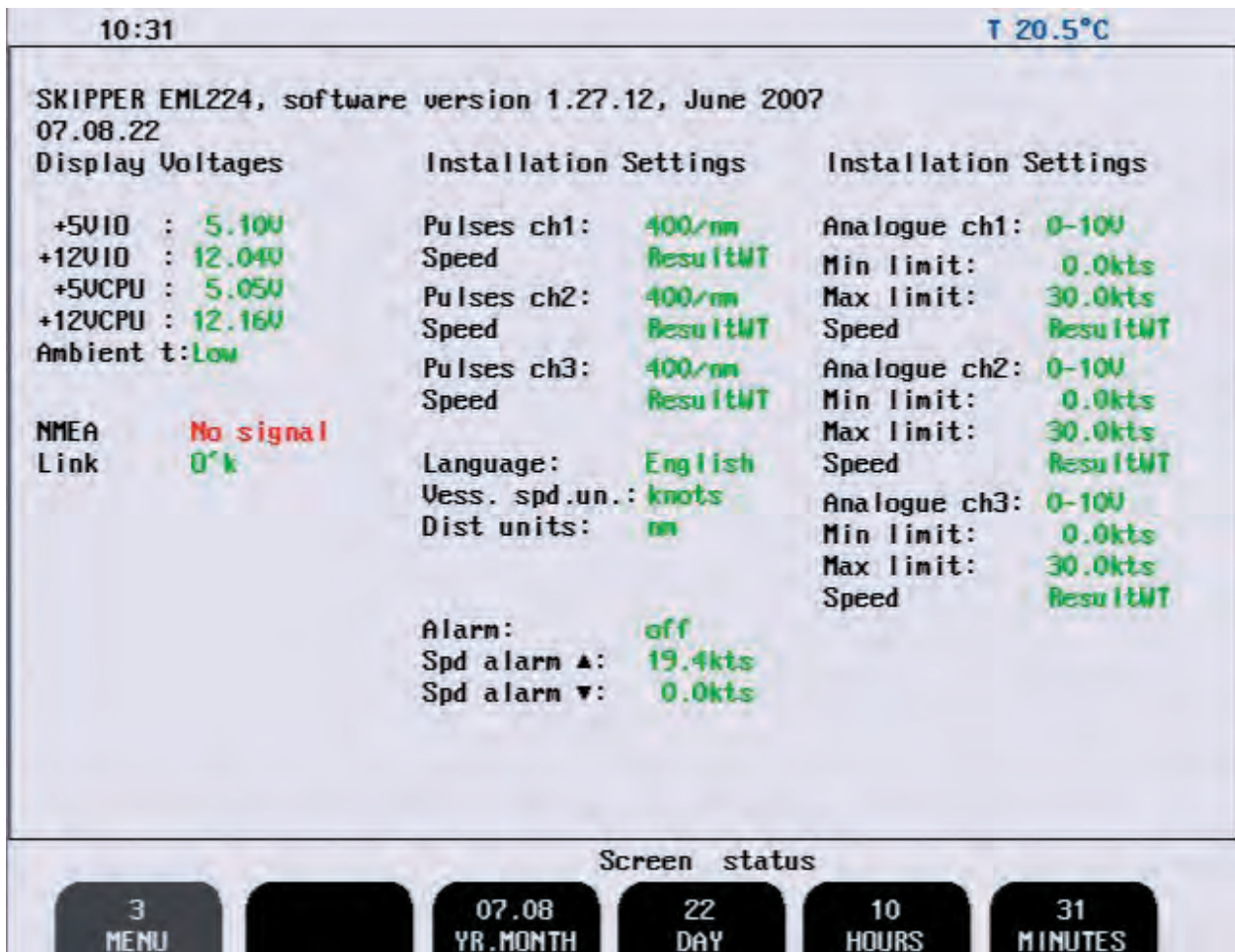

Fig. 2.9 Screen Status, Menu 3

Soft key 1: MENU	Chosen menu number 3
Soft key 2: Not used	
Soft key 3: YR.MONTH	Year and month setting
Soft key 4: DAY	Date setting
Soft key 5: HOURS	Hours setting
Soft key 6: MINUTES	Minutes setting

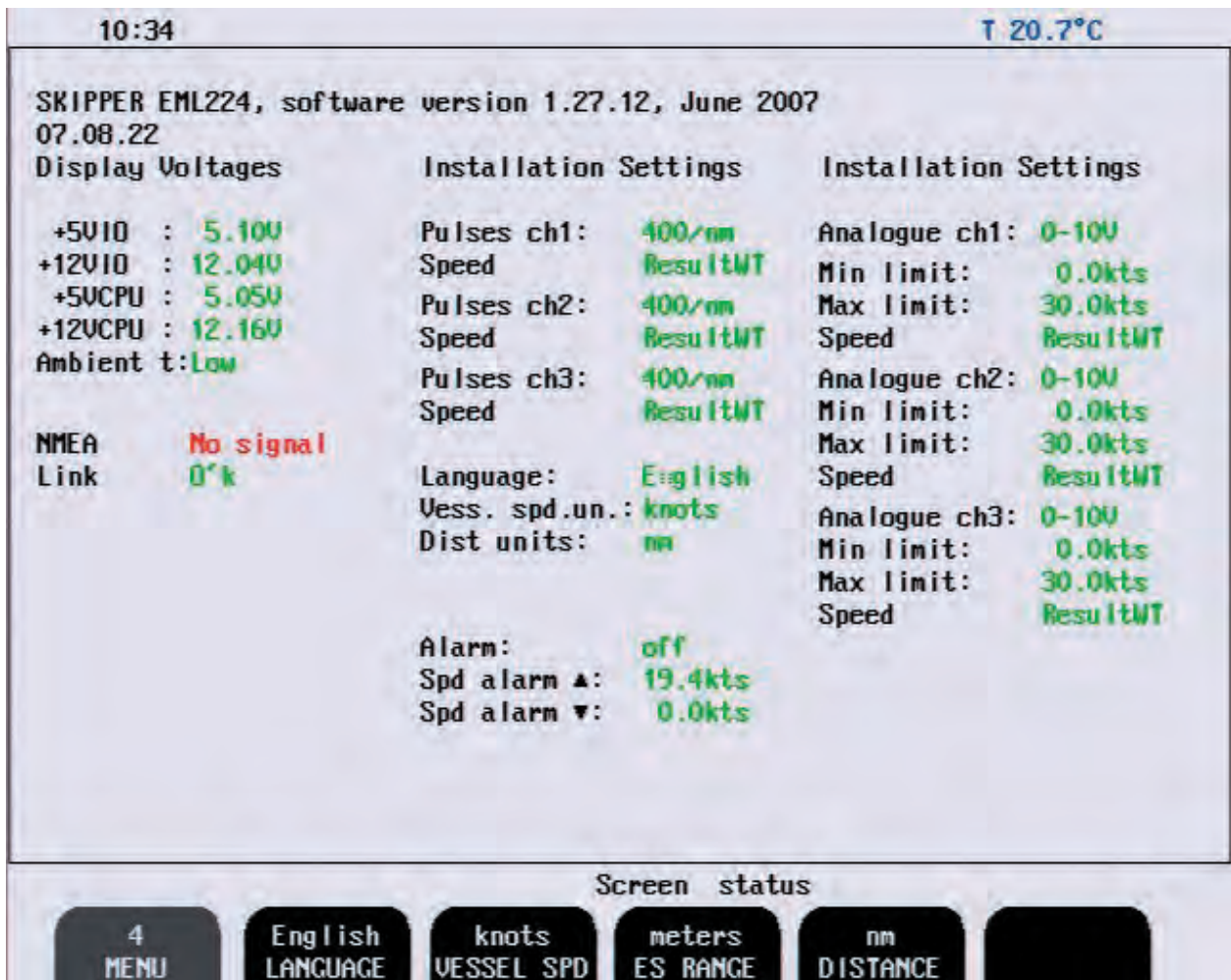

Fig. 2.10 Screen Status, Menu 4

Soft key 1: MENU

Soft key 2: LANGUAGE

Soft key 3: VESSEL SPD

Soft key 4: ES RANGE

Soft key 5: DISTANCE

Soft key 6: Not used

Chosen menu number 4.

Select Display Language:

[English, French, Spanish, Russian, German,Skandinav]

Select Speed Unit: [knots, km/h, mi/h, m/s]

Select Depth Unit: [meters, feet, fathoms, braccias]

Select Distance Unit: [nm, km, mi]

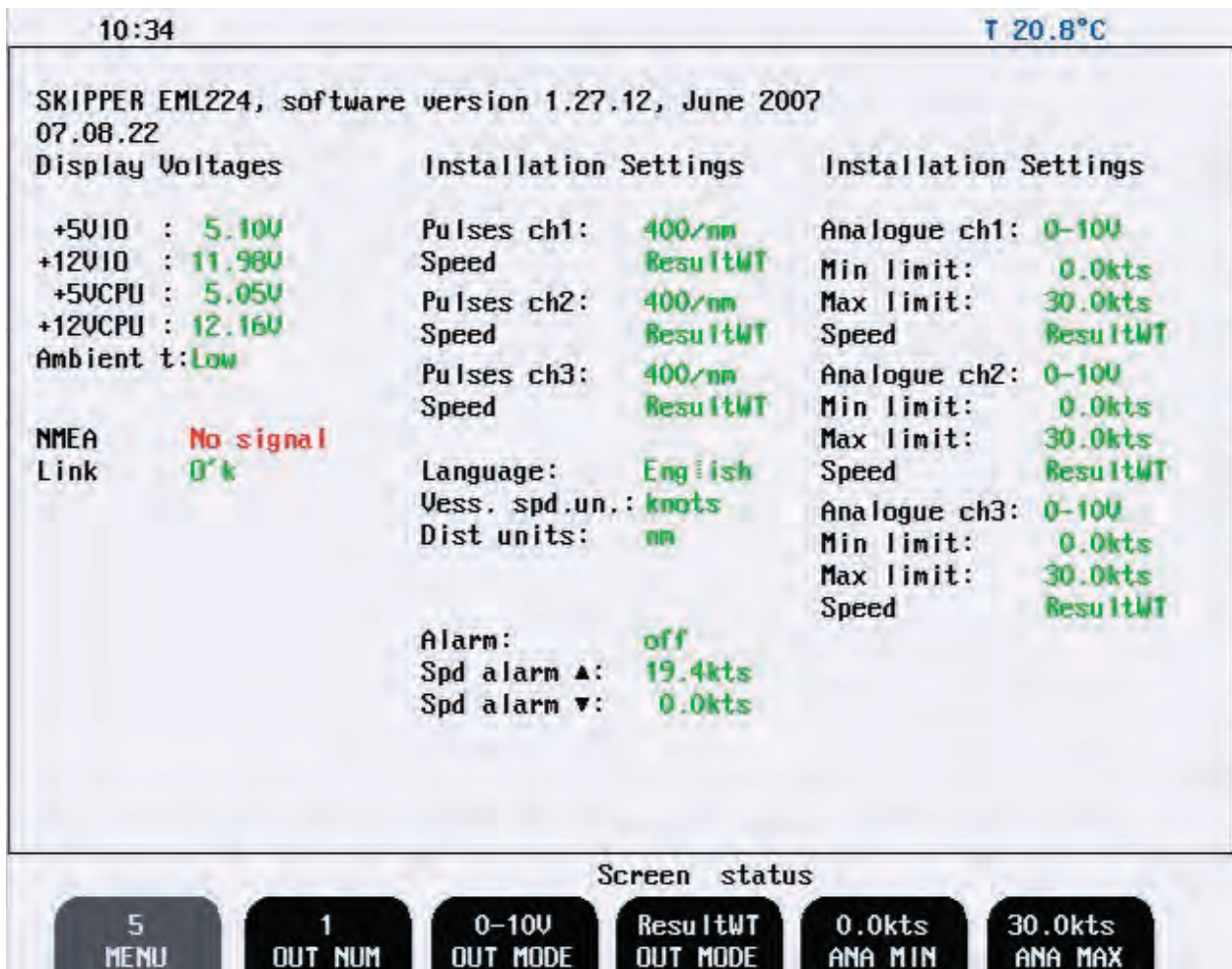

Fig. 2.11 Screen Status, Menu 5

Soft key 1: MENU	Chosen menu number 5
Soft key 2: OUT NUM	Analogue Output Channel to be configured by Keys 3-6: [ch1, ch2, ch3]
Soft key 3: OUT MODE	Output Mode Selection for this channel (Key 2): [0-10 V, 4-20 mA]
Soft key 4: OUT MODE	Speed Parameter to be output at this Channel (Key 2): [ForAftWT, Lateral/WT, ResultWT]
Soft key 5: ANA MIN	Speed Value for minimum Output at this Channel (Key 2): [-48-+48 kts]
Soft key 6: ANA MAX	Speed Value for maximum Output at this Channel (Key 2): [-48-+48 kts]

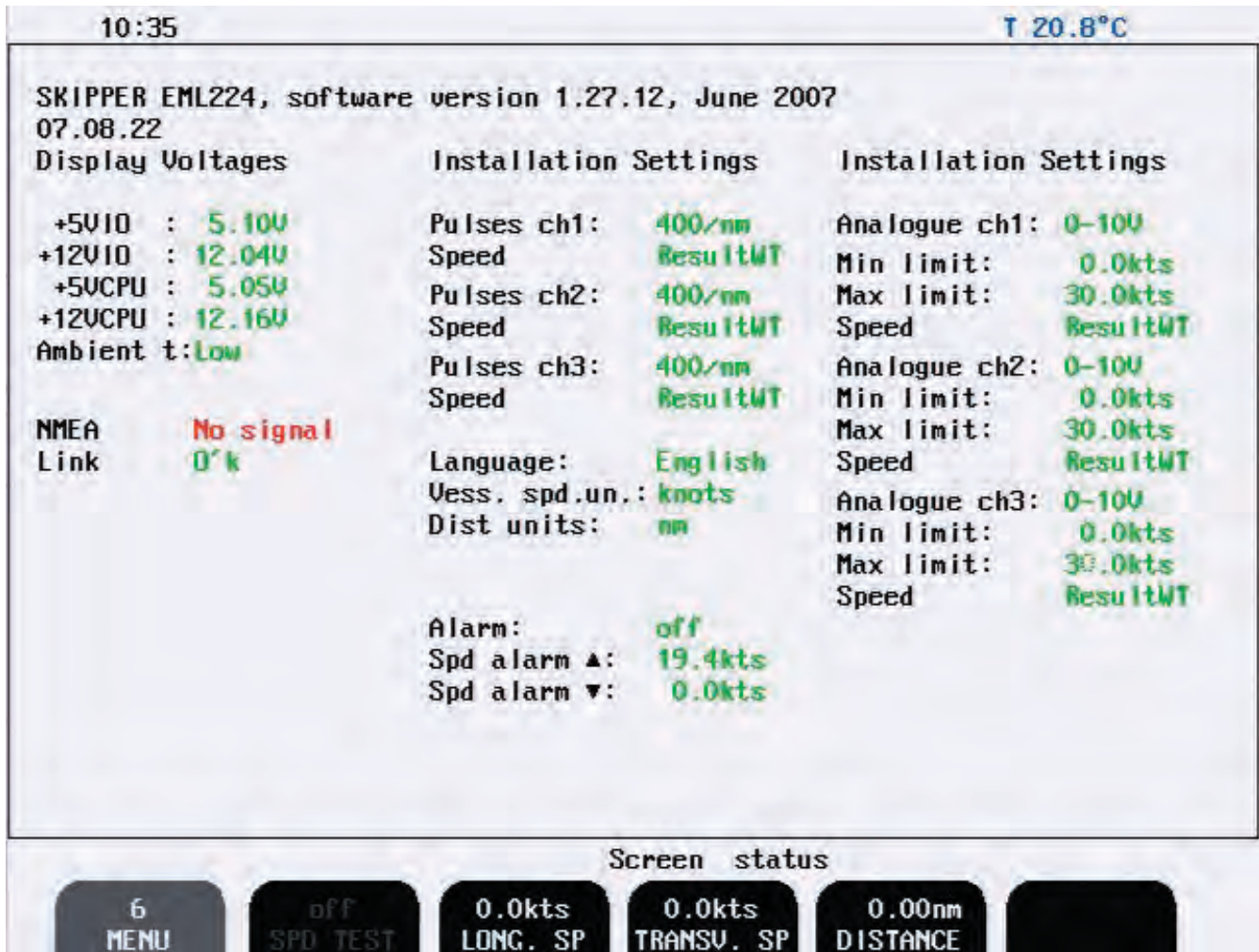

Fig. 2.12 Screen Status, Menu 6

Function described below can be used during commissioning period to exercise different EML outputs with constant, user adjustable speed values. **Note:** When the test mode is activated, this will be indicated by flashing “TEST” label in the lower left part of the screen.

Soft key 1: MENU	Chosen menu number 6
Soft key 2: SPD TEST	Toggling test mode on /off.
Soft key 3: LONG. SP	Select test value of longitudinal speed
Soft key 4: TRANSV.SP	Select test value of transversal speed
Soft key 5: DISTANCE	Select test value of distance.
Soft key 6: Not used	

Note: during normal operation SPD TEST soft key is disabled and can be activated by the mean of “hidden” button (ref “Activation of the calibration mode”).

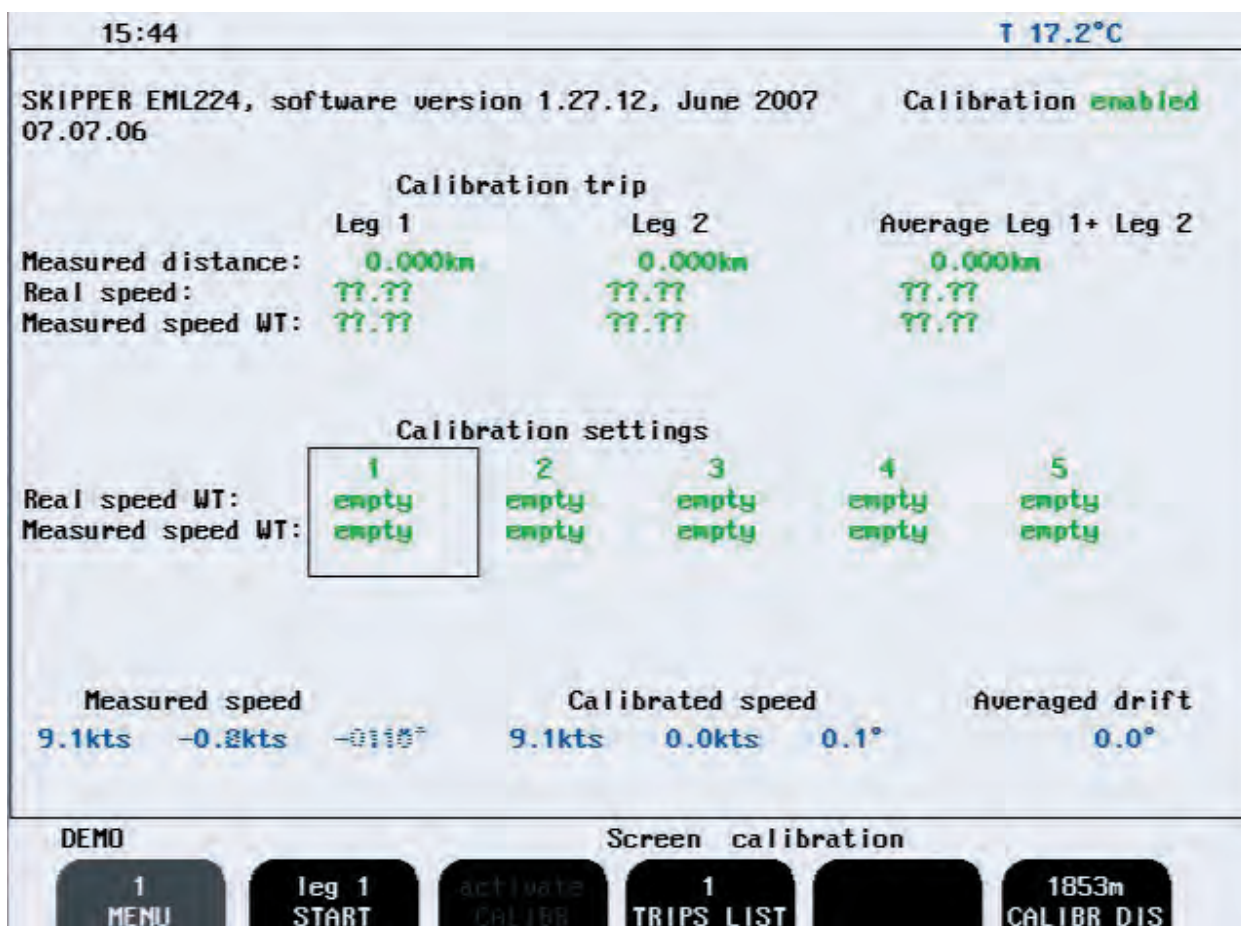

Fig. 2.12 Screen Calibration, Menu 1

Soft key 1: MENU	Chosen menu number 1
Soft key 2: START	Used to start/finish test trip
Soft key 3: CALIBR	Used to move data, collected during test trip into calibration table
Soft key 4: 1 TRIPS LIST	Used to list between different test trip data sets. Only one test trip is displayed on the screen at a time
Soft key 5: Not used	
Soft key 6: CALIBR DIS	Used to adjust length of the test leg.

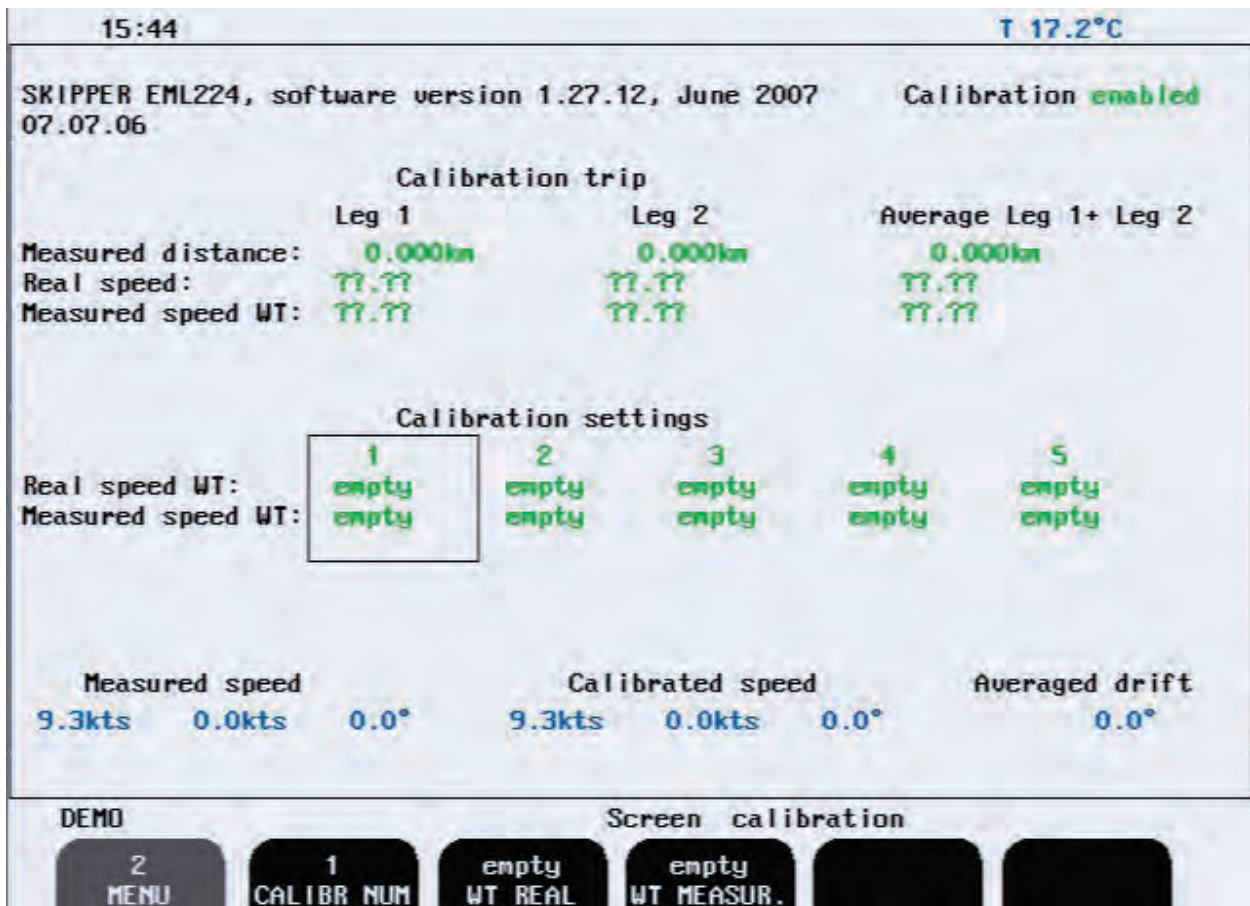

Fig. 2.13 Screen Calibration, Menu 2

Soft key 1: MENU

Soft key 2: CALIBR NUM

Soft key 3: WT REAL

Soft key 4: WT MEASUR

Soft key 5: Not used

Soft key 6: Not used

Chosen menu number 2

Number of the calibration, currently available for adjustments. In the calibration table it is marked by the frame.

Real ship's WT speed

WT speed, measure by the system (not calibrated)

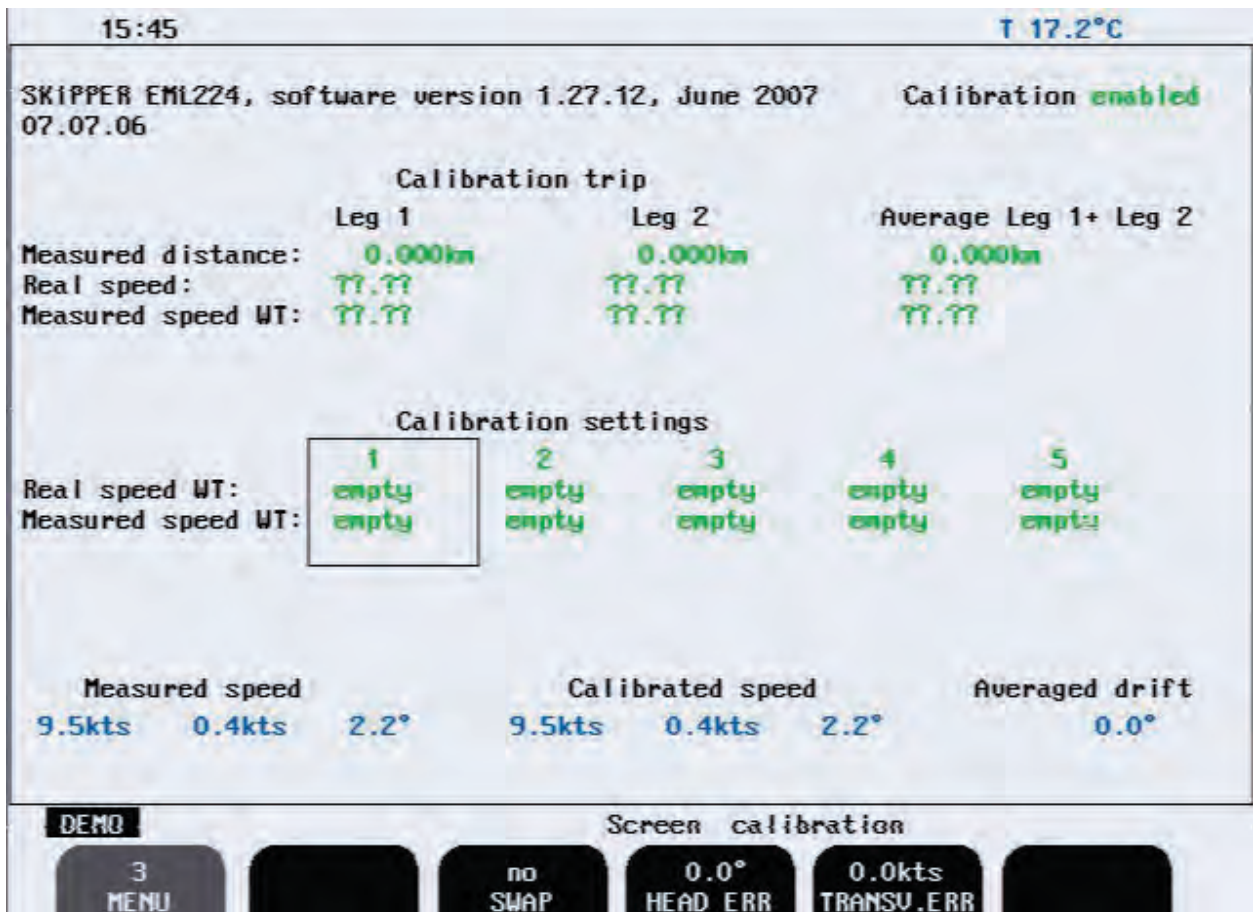

Fig. 2.14 Screen Calibration, Menu 3

Soft key 1: MENU

Chosen menu number 3

Soft key 2: Not used

Soft key 3: SWAP

Transducer elements swap.

Soft key 4: HEAD ERR

Installation angular error correction.

Soft key 5: TRANSV ERR

Installation transversal error correction.

Soft key 6: Not used

PRINCIPAL FUNCTIONS

Principles of Electromagnetic Log

The transducer of the Electromagnetic Log creates a magnetic field in the water. When the ship moves, the stream of water running along the hull cuts this magnetic field and generates a difference in potential between the transducer electrodes. This difference is directly proportional to the speed of the stream of water. Calibration of the log makes it possible to correct the difference between the water speed around the transducer and the speed of the ship. These difference being essentially linked to the positioning of the transducer in relation to the hull and also to the hull's shape.

Power ON/OFF

During normal daily operation, the system may be switched off from all operation menus. This operation does not disconnect the system from the power supply, but all power consuming components are switched off. The system may be switched on again by pressing any button.

Note: Do not run the EML224 sensor for a long time with the sensor in air. The sensor may be overheated and damaged.

Alarm acknowledgement.

When any alarm is activated, the alarm may be acknowledged by pressing any button. An alarm can also be silenced by using a remote alarm button but the alarm message will still be present until a button is pressed on the operator unit.

FIXED KEY FUNCTIONS.

Screen Select

The SCREEN SELECT button facilitates selection of one of the five screen and soft key layouts. The 2 primary operation screens may be cycled by repeatedly pressing the SCREEN SELECT button. Access to the remaining screens is through encoder operation. The screens are cycled in an endless, bi-directional loop, e.g. turning the encoder counter-clockwise, will open the last screen after the first screen.

Turning the encoder with no buttons pressed always force Screen A.

Backlight adjustment

Backlight may be continuously controlled by means of the appropriate buttons and the encoder. Press the button and rotate the encoder until a satisfactory setting is obtained, then release the button. The settings are maintained in the non-volatile memory, and the last settings are restored on power up. Backlight may be adjusted in both day and night vision.

Please note that if the backlight setting is reduced too much, the panel illumination may become uneven due to the backlight tubes not being properly ignited.

KEY FUNCTIONS.

Menu

The leftmost softkey is always used for selecting the desired menu, i.e. softkey layout within a screen. The different screens have a different number of menus, and some of the menu functions may be available on more than one menu. Below is a list of all menu functions, not necessarily in the sequence they appear on the screens.

Trip Reset

This key is used to reset the trip distance log.

Alarm settings

Speed alarm settings are performed from Status Screen, menu 1. Alarm limits are referred to the indicated speed and depth.

The local alarm buzzer may be disabled from Status Screen, menu 1, but the external alarm relay will always operate. The only way to disable the alarms completely, is to reduce the Low speed alarm to zero and increase the High Speed alarm to maximum range.

An active Low Speed Alarm must be less than an active High speed alarm. Alarm limits are enforced with hysteresis.

Clock and Calendar Settings

Manual Clock and Calendar adjustments are carried out in the Status Screen menu 3. If a Satellite navigator giving UTC messages is connected to the NMEA input, the clock and calendar will be automatically updated and manual adjustment is not required.

Simulator

The EML224 contains a built in simulator to exercise the screen indicators and various interface signals. The simulator may be switched on and off on Status Screen menu 1.

When the simulator is operating, "Demo" is flashing at the bottom of the screen.

Status Screen

The Status Screen shows a list of various system parameters useful for documenting system set-up and system operating status. The contents of this screen will be valuable information in situations where manufacturer support is required.

Non-volatile Parameter Memory.

The system contains non-volatile memory to maintain installation and user parameters like Language and units of measurement selection, backlight settings, etc.

These parameters are kept in EEPROM memory and are automatically restored on power up. If the user parameters have never been set, default values are used.

OPTIONS.

Repeaters/Slaves

Graphic display or digital depth slave repeaters may be connected to the system.

3. USER MAINTENANCE

TRANSDUCER MAINTENANCE.

The transducers are virtually maintenance free, but occasional cleaning may be necessary depending on sea water conditions.

OPERATOR UNIT MAINTENANCE.

The operator unit contains no user serviceable parts, and requires no maintenance apart from occasional cleaning of the front panel. Please use a soft cloth and no chemicals except cleaning alcohol.

4. INSTALLATION

STANDARD SYSTEM SUPPLY.

A Basic EML224 system consists of the following units.

- Operator Unit
- Junction Box
- Ball Valve with transducer (sensor)

See Chapter 8.Appendix, drawing: EML224 overview

HULL FITTING.

Please see installation manual for chosen valve or tank solution for dimensions and hull fittings.

TRANSDUCER LOCATION.

To facilitate the calibration procedure, the sensor should be installed close to the bulb or the stem of the ship, avoiding areas where it may be damaged by the anchor chain.

It is of course necessary to select a part of the hull that is submerged under all load and speed conditions.

The Junction box have to be installed in a dry place.

The Ball valve with sensor can be installed in a water tank, but it is not recommended.

SKIPPER will not be responsible if it is necessary to empty a tank in order to access the sensor for service purposes.

It is necessary to position the sensor on a flat, horizontal hull section which is large enough to ensure a laminar water flow for all angles of drift.

If such a flat section is not available, the shipyard must construct a suitable bed.

If the vessel is designed with a box keel, this can be used for installation of the dual axis sensor.

In this case, special length hull fitting and sensor may be ordered from SKIPPER.

Before hull fitting installation procedure is initiated, always check that the hull fitting valve can be

properly operated and the sensor removed in the location selected.

The required clearance to operate the valve and remove the sensor is shown in Fig. 4.1.

See installation manual for the valve solution for more information.

PART POSITIONING AND WELDING.

Please see the Installation Manual for the valve.

Installation may differ between the different valve solutions available.

REQUIRED ELECTRODES

Steel hull: Type SAF 24, 12 or. Equivalent

Aluminium hull: Filler metal = AG4 or AG4 MC.

WELDING PRECAUTIONS.

Separate the bottom flange from the remaining hull fitting assembly before welding.

Use a board to ensure that the bottom flange is flush with the external surface of the hull.

Before welding, remove the O-rings. Remember to apply grease when refitting them.

After welding, check that the outer weld filling has been properly ground down. Paint the hull fitting as well as the hull itself with a suitable anti-corrosion/anti-fouling product, but do not paint the protruding part of the sensor and electrodes.

Clean the electrodes with ethanol or iso-propanol before fitting the transducer.

TRANSDUCER INSTALLATION.

Please see the Installation Manual for the valve.

Installation may differ between the different valve solutions available.

THE JUNCTION BOX.

The junction box contains the power supplies for the transducer. It must be installed fairly close to the hull fitting as the standard cable is 30 or 40 meters. The junction box should be fitted on a vertical surface in a dry area.

See chapter for MISCELLANEOUS INSTALLATION DRAWINGS.

TRANSDUCER/JUNCTION BOX INTERCONNECTION.

The transducer is connected to the junction box with the supplied cable.

The outer cable screen must be connected to the EMC cable gland.

The wires are identified with numbers or colours according to the following table.

Cable:

<u>No</u>	<u>Colour</u>	<u>Signal</u>
1	NC	0 VOLT
2	NC	+ 5V
3	NC	+ 12 V
4	NC	- 12 V
5	BLACK	24V NEG
6	WHITE	24V POS
7	YELLOW	RX+ CLI
8	BLACK	RX- CLI
9	NC	TOP+CLI
10	NC	TOP- CLI
11	WHITE	TX+ CLI
12	ORANGE	TX- CLI

Note:

There exists several types of cables. Contact SKIPPER for more information about these cables.

Supply for the junction box and transducer is 230V AC and 24V DC as standard. It may be configured for 115V AC on request. Or do the following :

230VAC = R102 0R and R100+R101 not mounted

115VAC = R102 not mounted and R100+R101 = 0R

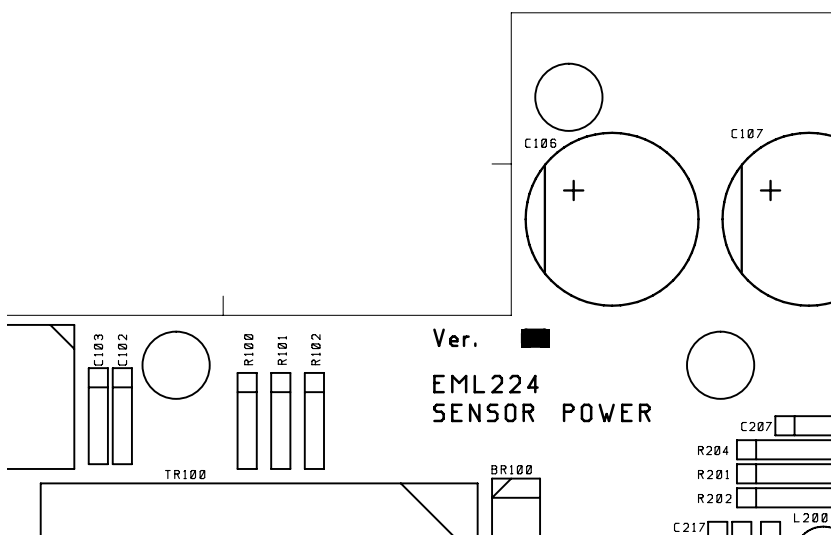

The circuit board in the junction box is equipped with several LED lamps indicating the state of various voltages and signals. In order to facilitate trouble shooting, a list of the LEDs and a description of their function is given in the following table. Fig. 4.6 shows the location of LED lamps and fuses.

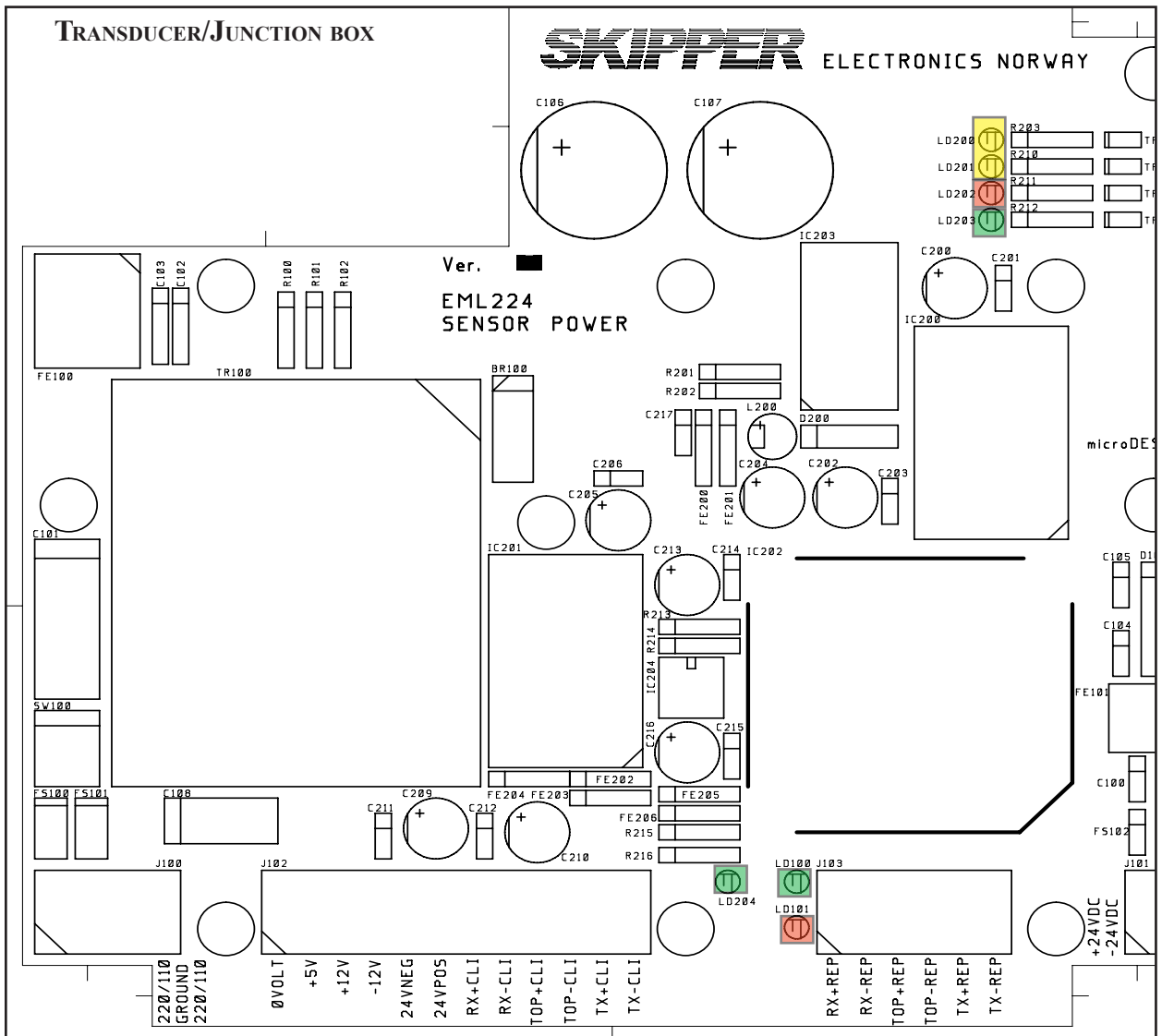

Fig. 4.2 Sensor Junction box, Location of Fuses and LEDs.

<u>LED</u>	<u>Colour</u>	<u>Signal</u>	<u>Function</u>	
LD200	Yellow	9V	Voltage indicator	Not in use
LD201	Yellow	14V	Voltage indicator	Not in use
LD202	Red	-14V	Voltage indicator	Not in use
LD203	Green	24V	Voltage indicator	
LD204	Green	Current	Flashing at 2 Hz with the field inducting current.	
LD101	Red	RS422	Flashing when sensor receives data from display unit (only during programming).	
LD100	Green	RS422	Flashing when sensor transmits data to Display Unit.	

If all LEDs are out, check fuses FS100 and FS101.

OPERATOR UNIT INSTALLATION.

Select a position to provide free view of the panel as well as easy access during operation and service. The operator unit may be mounted flush in a panel or directly onto a bulkhead. Fig. 4.7 shows the operator unit along with the main installation dimensions.

If the unit is to be flush mounted, the shown cut-out and recession depth dimensions must be observed.

Remember to leave room in front of the unit to open the door a full 90°

Do not perform installation work with system power applied!!

Cables are led through the appropriate cable glands as follows:

The cable from the transducer(s) should normally occupy the left gland. The right gland is used for power supply connection whereas the centre ones are used for any interface signals connected.

Power supply may be either 115V/230V AC or 24V DC. Power consumption is appx. 50 W at 24V, appx. 70W at 115/230V.

The transducer is always connected with 1 pair plus screen. See Fig 4.11.

If the AC power system is 115V, EML224 may be prepared for 115V AC by re-connecting the connectors J102, J103 as shown in Fig. 4.8.

This diagram also shows position of fuses for 115/230 VAC and 24 V DC. These fuses are normal 5 x 20 mm slow blow glass fuses.

AC supply:	FS100, FS101	230V	0.5A
		115V	1A
DC supply:	FS102	24V	3.15A

When the installation is complete, and power is connected to the Operator Unit, the appropriate power switch by the power terminals is switched on. For daily operation, these switches may stay on and the unit is switched off by pressing the “SYSTEM off” button on Screen A or Screen B. The unit is switched on by pressing any button.

Both 115/230 VAC and 24V DC power may be connected and switched on at the same time. If one of these supplies shuts down, changeover is automatic.

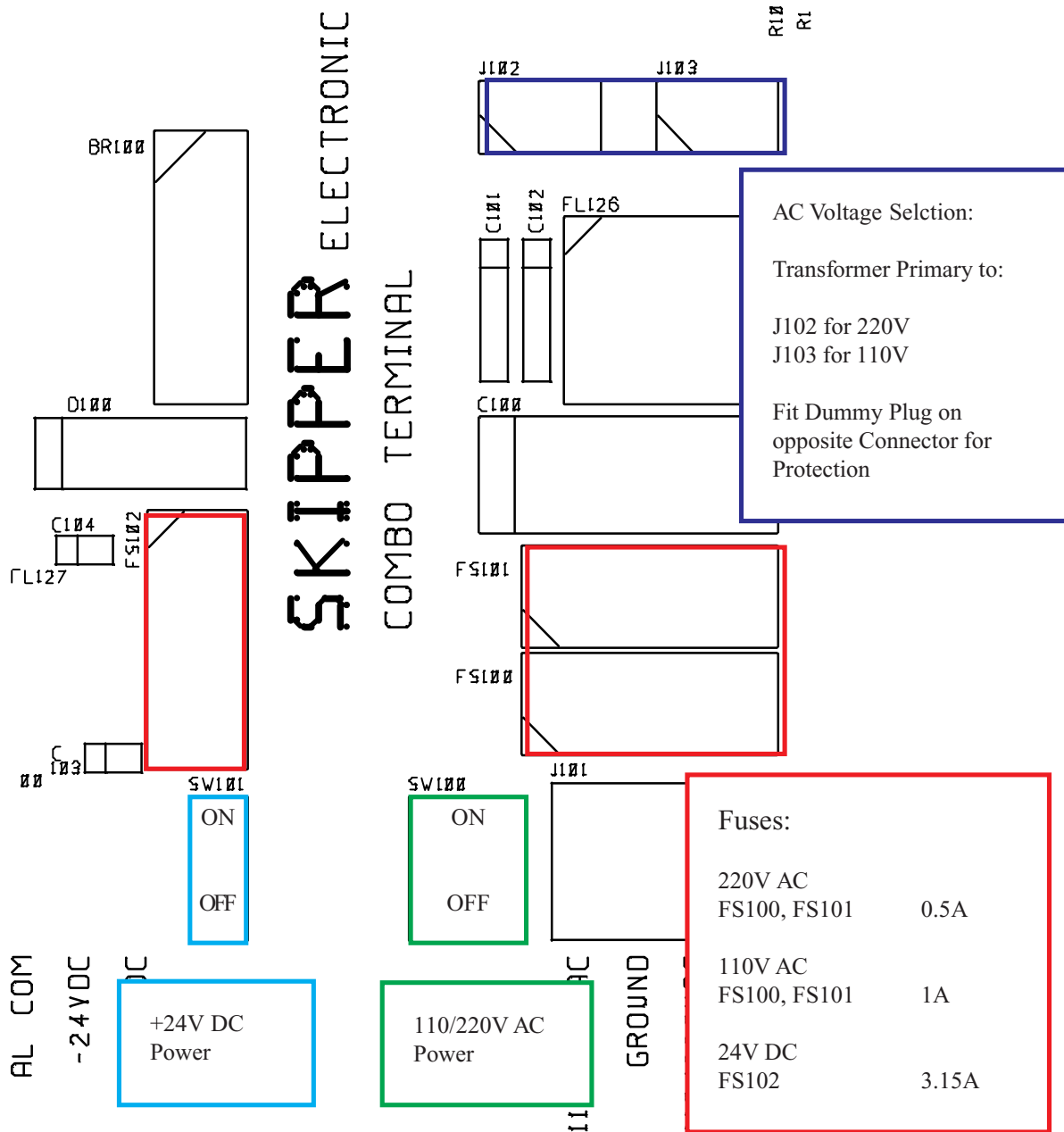

Fig. 4.3 Voltage selection connectors and fuses, Terminal Board.

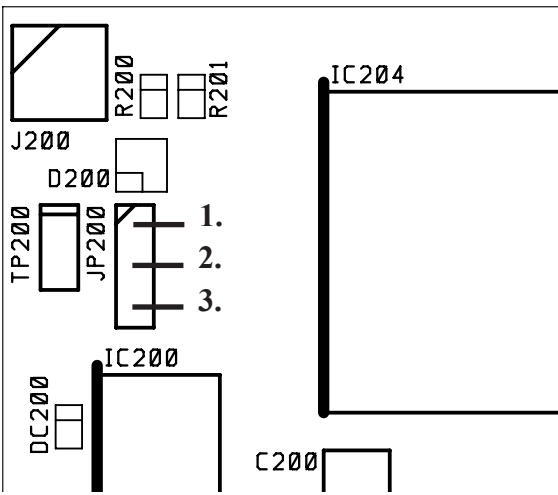
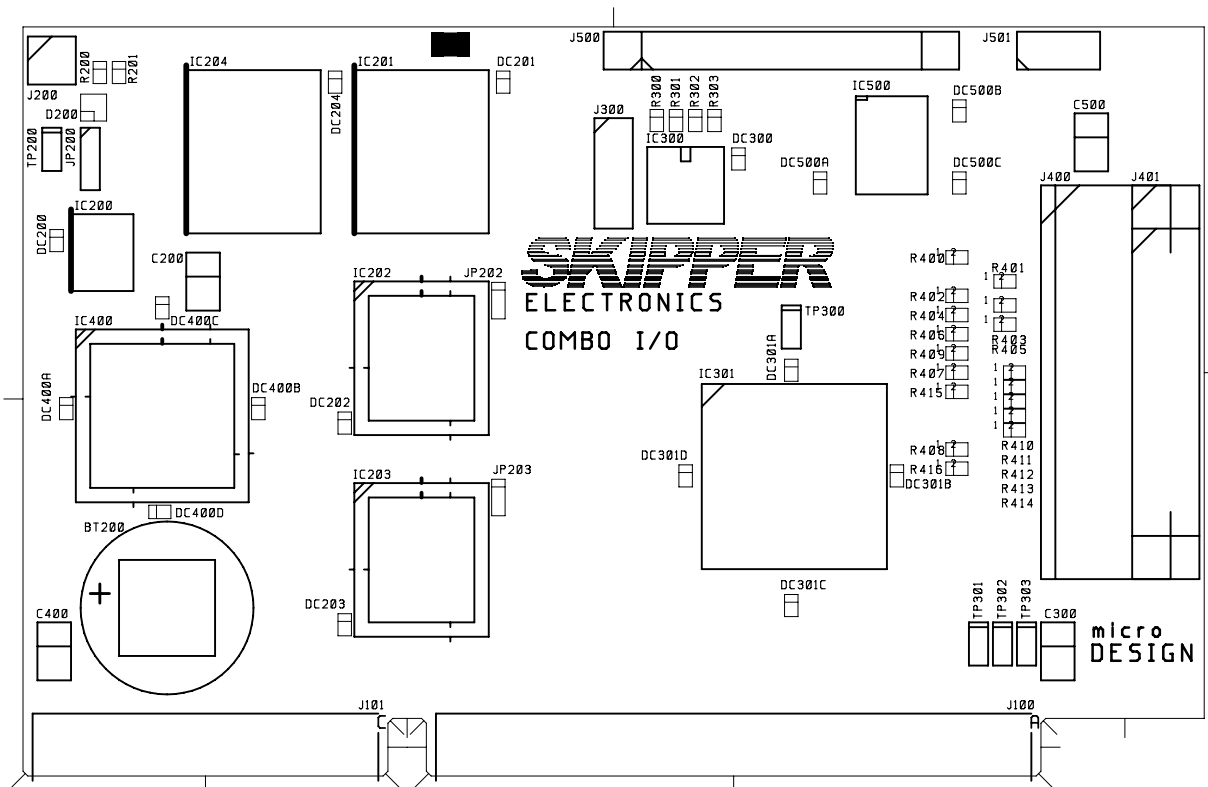

Fig. 4.4 History Memory Battery Jumper, I/O Board.

BACK-UP BATTERY JUMPER 200

After installation is complete and system power is applied, it is necessary to connect the history memory battery to provide power to the circuitry containing user parameters at a system power failure. Refer to Fig. 4.9 for the correct setting of the battery jumper “ON” position 2-3. This jumper should be set to the “OFF” position 1-2 only during extended unit storage periods. The onboard battery is loaded only when no power is applied to the power terminals.

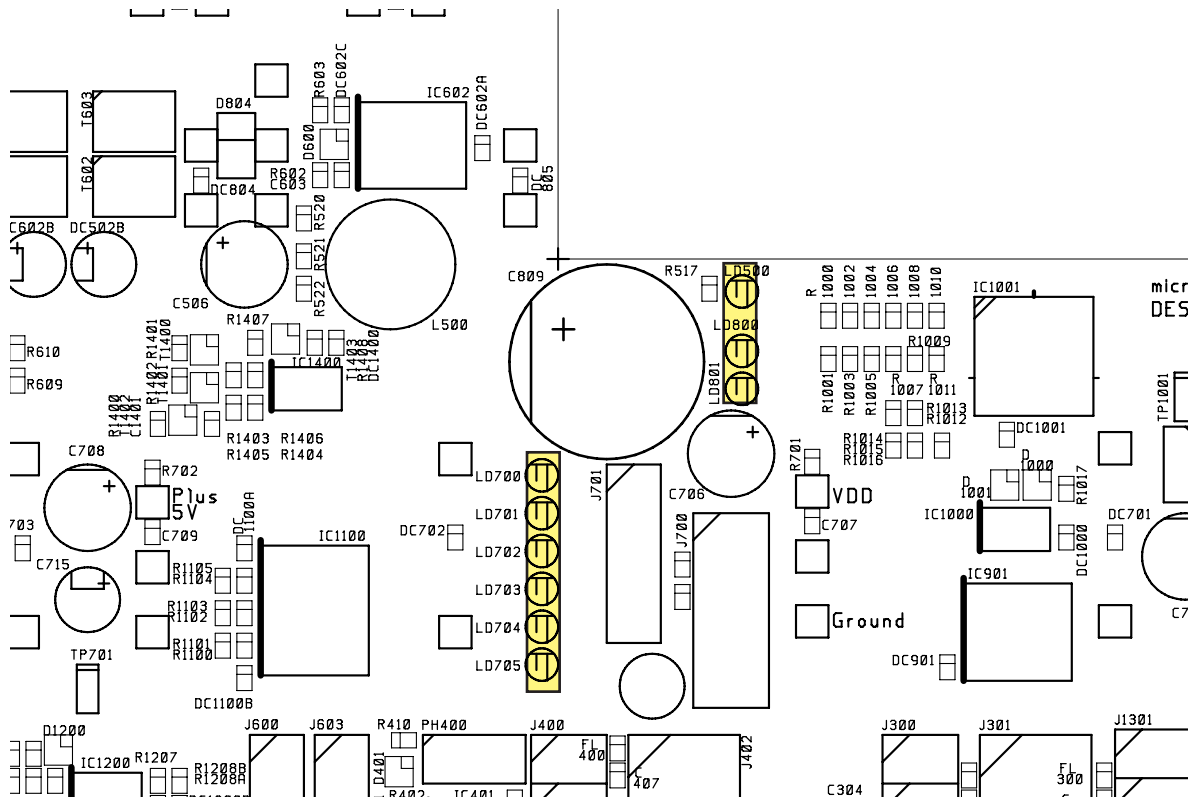

Fig. 4.5 Function LED's, Terminal and CPU Boards.

Power Indication and function LED's.

The following LED's are located on the Terminal Board:

- LD700 +5V#1/VCC (Board External and CPU)
- LD701 +12V#1/VDD (Board External)
- LD702 +5V#2 (Board Internal)
- LD703 +12V#2 (Board Internal)
- LD704 -12V
- LD705 -5V
- LD800 +24V Auxillary (Not used on EML224)
- LD801 +48V/132V Auxillary (Not used on EML224)
- LD500 Auxillary Function (Not used on EML224)

INTERFACING.

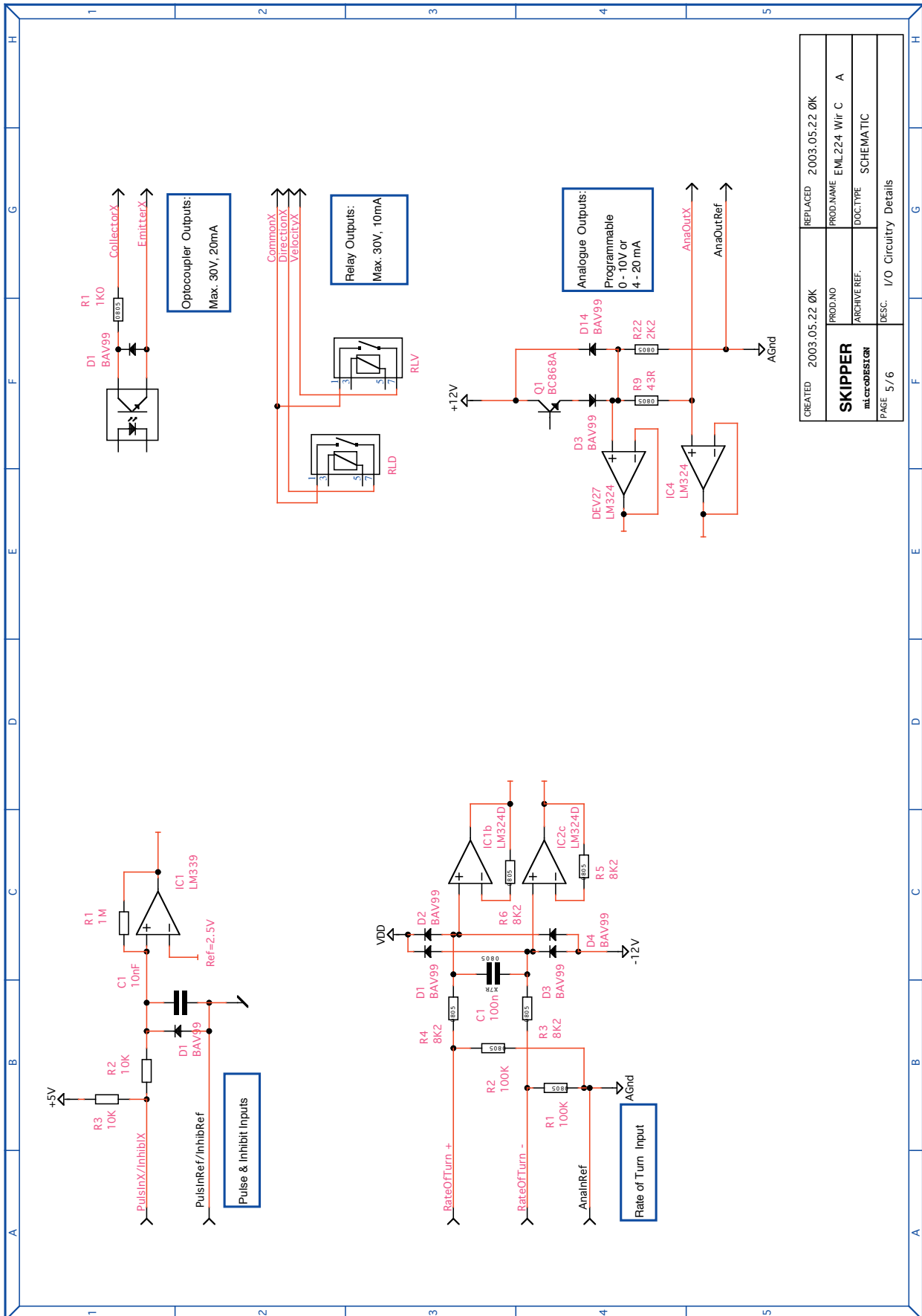

Fig. 4.6 Input/Output Circuitry.

Interfacing.

ALARM RELAY

An alarm relay is provided for interconnection to external alarm systems. This relay is normally energised, and is released by alarm conditions or power failure/power off. See Appendix for drawing.

The terminals have the following significance:

ALCOM	Common Terminal.
ALNC	Normally closed Contact (Normal = "No alarm" condition)
ALNO	Normally open Contact
INHIBREF	Reference for Remote Alarm Reset
INHIB2	Remote Alarm Reset

LOG PULSE OUTPUTS

Pulse output terminals are as follows. Each group of pulse outputs are galvanically separated. All pulse outputs are Opto Couplers. The Opto Couplers may be used for any pulse rate. The pulse rates and velocity vectors to output are programmable in Status Screen, Menu 3 : (possible settings are 10/100/200/400/1000)

Opto Coupler Direction Output, Transistor Off = AHEAD or STARBOARD

EMITTER	Direction Opto Coupler Emitter
COLLECTOR	Direction Opto Coupler Collector

Opto Coupler Velocity Output

EMITTER	Velocity Opto Coupler Emitter
COLLECTOR	Velocity Opto Coupler Collector

ANALOGUE INTERFACES

EML224 is equipped with 3 analogue outputs to supply analogue repeaters or other equipment with analogue inputs. The signals are galvanically connected to the EML224. Standard range is 0 - 10V or 4 - 20mA.

The velocity vectors and output modes are programmable from Status Screen, Menu 5:

ANAOUTREF	System Ground, common negative Reference for Analog Outputs
ANAOUT1	Analog Output #1
ANAOUT2	Analog Output #2
ANAOUT3	Analog Output #3

NMEA INTERFACE

The NMEA outputs provides NMEA0183 format speed information for other equipment with NMEA0183 inputs. Standard Com settings is 4800 baud, 8 bit, no parity. Several messages may be selected on Com Screen and the enabled messages are transmitted every second.

The NMEA inputs accept position, heading and UTC time messages from various navigators and compasses.

The two inputs provided may be connected to different talkers, and both data streams will be received.

There are two output that will drive minimum of 10 standard NMEA0183 inputs.

See Chapter “**Start-up and system adaption**”, for a complete list of transmitted and received messages.

OPTIONS.

Repeaters/Slaves

Graphic CRT(VGA) or LCD displays or digital speed slave repeaters may be connected to the system.

Skipper IR300 speed repeaters may also be connected, interface NMEA0183

5. START-UP AND SYSTEM ADAPTION

ANALOGUE OUTPUTS AND LOG PULSE OUTPUTS RANGE SELECTION.

From Status Screen menu 2, it is possible to set number of pulses per nautical mile (p.p.n.m.) for the 3 available contact closure output channels (Ch) :

Ch1 and Ch2 : 10, 100, 200 or 400 p.p.n.m.

Ch3 : 10, 100, 200, 400, or 1000 p.p.n.m.

(the selected p.p.n.m. for each output is shown in Status screen)

Minimum and max limits for the analogue outputs may be set to:

Maximum speed -30/+30 knots corresponding to 10 V or 20 mA and

Minimum speed -30/+30 knots corresponding to 0 V or 4 mA.

LANGUAGE AND UNITS OF MEASURE

From Status Screen menu 4 it is possible to select different languages and units of measure for the screen and printer character strings.

The available languages are: English, French, Spanish, Russian, German and Norwegian.

Units of measure may be selected for:

Vessel Speed: knots, km/h, miles/h, m/s.

ES Range meters, feet, fathoms, braccias

Distance nm,km,miles

NMEA SETUP

Com Screen is used for verification of received NMEA messages and control of transmitted NMEA depth messages. The baud-rate may be set to 4800 or 9600, 4800 being the more common.

When a NMEA talker is connected to one of the EML224 inputs, all received messages will be displayed on the screen.

If no messages are displayed, check the signal polarity and the baud-rate.

The following messages are accepted for input to EML224 and interpreted by the program. The talker identifier is ignored:

Time

Universal Time ZZU,xxxxxx

Universal Time & Local ZLZ,xxxxxx,xxxxxx,-xx

Day, Month, Year ZDA,xxxxxx,xx,xx,xxxx,-xx

.
. .
. .
. .
. .
. .
. .

Position

Geographical Lat/Lon	GLL,xxxx.xx,N,xxxxx.xx,W
Geographical Fix, present	GXP,xxxxxx,xxxx.xx,N,xxxx.xx,W,cccc,x
Omega Fix, present	GOP,xxxxxx,xxxx.xx,N,xxxx.xx,W,cccc
Loran C Fix, present	GLP,xxxxxx,xxxx.xx,N,xxxx.xx,W,cccc
GPS Position	GGA,xxxxxx,xxxx.xxx,N,xxxxx.xxx,W,x

Heading

Heading, true, present	HDT,xxx.,T
Heading, magnetic, present	HDM,xxx.,M
Heading, compass	HCC,xxx.

Composite

Loran C specific	RMA,a,xxxx.xx,N,xxxxx.xx,W,,xx.x,xxx.,*xx
GPS, Transit specific	RMC,xxxxxx,a,xxxx.xx,N,xxxxx.xx,W,xx.x,xxx., xxxxxx,*,*xx
Vessel Identification	IMA,aaaaaaaaaaaa,aaaxxxx,xxxx.xx,N,xxxxx.xx,W, xxx.x,T,xxx.,M,xx.x,N

EML224 TRANSMITTED(ORIGINATED) NMEA0183 MESSAGES

VHW

Boat Speed and Heading

\$VDVHW,,,,,x.x,N,x.x,K*hh<CR><LF>

VLW

Distance Travelled through the Water

\$VDVLW,x.x,N,x.x,N*hh<CR><LF>

MTW

Temperature

\$VDMTW,x.x,C,*hh<CR><LF>

All data fields are free format.

Values will be preceded with sign as needed (e.g “-“ = Astern, Port)

*hh = Checksum

SPEEDLOG CALIBRATION PROCEDURE

EML224 speed error can be caused basically by 2 reasons: Angular sensor installation error and different way of water propagation along the hull, which depends on the hull's shape and vessel's speed.

All calibration functions are concentrated on the calibration screen. In order to select this screen, push "screens" button in the lower row of the panel buttons and keeping it pressed, turn encoder until desired screen appears on the display.

ACTIVATION OF THE CALIBRATION MODE.

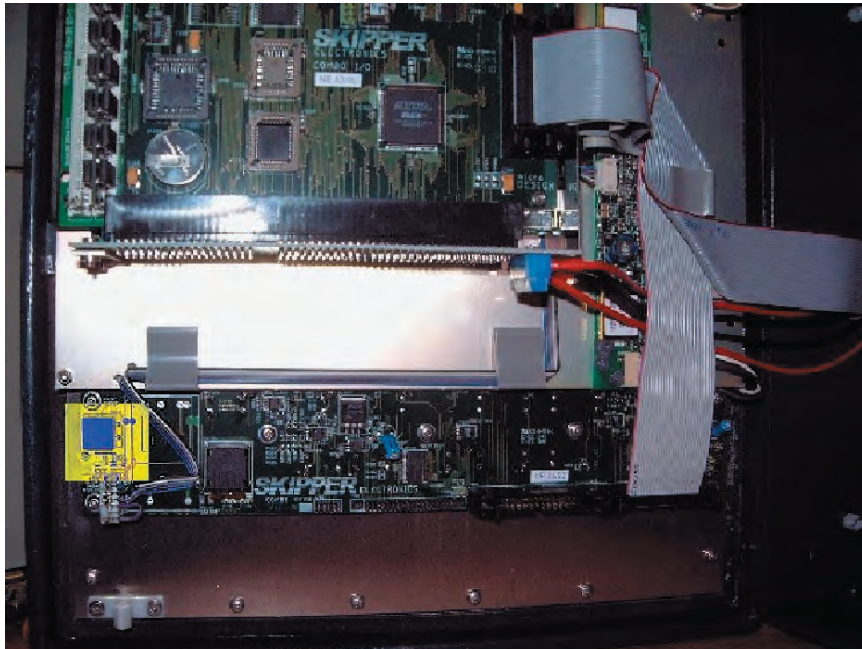

Fig 5.1. Hidden key inside door of Operator unit

To avoid accidental access to the internal settings by unqualified personal, all calibration functions are disabled during normal operation. In order to activate them, one should do the following:

- Open front door of the cabinet and find a "hidden" key on the component side of the keyboard PCB (upper/left corner of the PCB).
- Press key mentioned above, and keep it pressed for 2-3 seconds, until "Calibration enabled" message is observed in the right/upper corner of the screen. The text on the "soft" keys will change colour from grey to white, which indicates availability of the corresponding functions.

Note: After calibration is finished, disable access to the calibration functions simply by pushing mentioned above button. Calibration mode is also disabled after power down.

INSTALLATION ANGULAR ERROR CORRECTION.

Before conducting speed calibration trips, it is recommended to set compensation for installation angular error. To do this, the vessel should sail with a constant speed (preferably 50% of full speed or higher) at constant direction for 2-3 minutes. The impact of wind and waves must be minimal. The averaged measured drift angle is indicated in the lower/right part of the calibration screen.

- Remember the value of the averaged drift angle.
- Select MENU 3 of the calibration screen.
- By the mean of “HEAD ERR” button set the value of the drift angle, (the sign must be the same).
- Make sure, that averaged drift angle now is slightly fluctuating around 0. If necessary, adjust HEAD ERROR parameter accordingly.

SPEED CALIBRATION TRIP.

Speed calibration during the test trip can consist of 3 steps:

1. Collect calibration data set during test trip. This data is a pair of real (reference) speed of vessel, calculated as a ratio of known distance to known time, and a speed, measured and averaged by the speedlog during the whole test trip.
2. If the result of the test trip is satisfactory, currently received trip data set must be stored in the calibration table.
3. If required, the calibration table can be adjusted manually.

To conduct the calibration, follow instructions below.

- Select MENU 1 on the calibration screen.
- Find out the distance length of the test trip and adjust the value accordingly by the mean of “CALIBR DIS” button. The preset (single touch activated) values of this button correspond to $\frac{1}{4}$, $\frac{1}{2}$, 1 and 2 nm. It is possible to enter any value by the mean of encoder.
- Check the status of soft key number 2. Before forward leg, the setting must be START/leg1.
- When passing the start mark of the test mile, push START/leg1 button. Button will change the value to “FINISH/leg1”. The trip start date/time will be indicated and the distance ran since the start of the trip will be counted in the “Calibration trip” screen area. Push the same button second time after reaching the finish mark. The calculated and measured averaged speeds are printed on the screen in the calibration trip area.

Note: If because of wrong settings or incorrect operation, calculated speed occurred to be higher than possible maximum speed (40kts), all information is considered as incorrect, which is indicated by question marks on the screen. The trip must be repeated in this case.

- For more accurate speed calibration it is necessary to conduct a backward trip to exclude possible influence of wind and current in the test area. Just repeat the previous step by pressing START/leg2 and FINISH/leg2 when passing the start and finish marks accordingly.

Note: If for some reason, only one leg is used, it is necessary to skip the second one just by pressing 2 times mentioned above button.

Note: In case, if it is necessary to repeat backward leg, while keeping forward leg information unchanged, press START/leg1 button and keep it pressed 3-4 seconds until the button changes its status to leg2. Then it is possible to conduct backward leg as described above.

- The both-ways average speeds are calculated now, and available for setting in the calibration table. To enter set of trip data into calibration table, press “CALIBR/activate” button. The frame in the calibration table is a graphic presentation of currently available entry in calibration table.

Note: It is possible to store the same data set in the calibration table only once, that’s why the “Calibr/activate” button changes its status to “unavailable”, which is indicated by a grey text colour on the soft key.

Note: Trip data set becomes active and is used for calculations of calibration factor, ONLY AFTER storing it in the calibration table.

- To achieve more accurate indication, it is recommended to run calibration trips at several different speeds, normally 25%, 50%, 80% and full speed. It is possible to enter up to 5 different settings in the calibration table. Piece-wise linear interpolation is used for speed correction at other, than calibrated values.

Note: If it is required to replace one of the existing calibration settings by another trip data set, it is necessary to delete the existing one first. Ref “Manual adjustment of calibration table”

- The speedlog store information about five last test trips (along with date/time, when they were conducted). It is possible to call them one by one on the screen later (even after power was OFF) by means of the “TRIPS LIST” button. Once trip data set is called on the screen, it is possible to store it in the calibration table (if it has not been entered before and there is available entry in the table).

MANUAL ADJUSTMENT OF CALIBRATION TABLE.

If it is required to make changes in the calibration table, received after calibration trips, or for some reason calibration trips haven't been conducted, it is possible to adjust calibration settings manually. In last case, DGPS speed can be used as a referenced (real) speed, but the impact of wind, waves and current must be insignificant.

To use this functions,

- Select menu 2 by MENU button.
- Select any of the entries in the calibration table by means of the "CALIBR NUM" soft key. The frame in the "Calibration settings" table will indicate currently selected entry.
- If DGPS speed is used as a run-time reference, this value should be entered by "WT REAL" button and corresponding measured speed, indicated under "Measured speed" text must be entered by means of the "WT MEASUR." button. Make sure, that "Calibrated speed" value corresponds now to reference value.
- If more than one calibration value is required, select another entry and repeat the step above. Maximum possible settings are 5

Note: To delete the entire entry in the calibration table, select it by "CALIBR NUM" soft key, push either "WT REAL" or "WT MEASUR." buttons and keep it pressed for 3 seconds, until settings change to "empty".

Once calibration is completed, it is advisable to write down calibrations settings in a table, attach it to the operators manual and keep it for later reference.

6. SPECIFICATIONS

Dimensions

Transducer Mounting	H * W * L Gatevalve Cable length	Depending of type used 40m
Junction Box	H * W * L Weight	120 * 300 *300 mm appx.6 kg
Operator unit cabinet	Height, front Width Depth Weight	340 mm 320 mm 170 mm appx.10 kg
Operator Unit Cabinet, Cut-out for flush Mounting	H x W Corner Radius	322 x 302 mm 4 mm

FUNCTIONAL PROPERTIES

Display:	10,4” 158 x 211 mm TFT LCD. 640 x 480 pixels.
Speed Alarms	High and Low Limits.
Calendar/Clock	Year-Month-Day / Hours-Minutes (24 hour system).
Interface Outputs	Pulses for Speed. Analogue 4-20 mA and 0 - 10 V for Speed. NMEA 0183 for Speed. Alarm Relay. Output for VGA Repeater. RS-232 C as option.
Interface Inputs	NMEA0183 for Position, Heading and Time.
Languages	English, French, Spanish, Russian, German and Norwegian.
Options	Digital repeater.

PERFORMANCE

Trip counter	Measurement from 0 to 99 999,99 nautical miles.
Distance accuracy :	0,2 nm or 2% whichever is greater.
Speed accuracy :	0,2 nm or 2% whichever is greater.
Speed range :	+/- 40 kts.

Speed measurement is done directly on the sensor surface, comply with IMO Res.A.824/A1.1

Rolling :	more than +/- 10 degrees
Piching :	more than +/- 5 degrees

The performance will depend on turbulence, aeration and sea conditions.
These effects may lead to occasional incorrect indication of speed and distance.

Environmental according to IEC60945 :

Operator Unit Cabinet

Supply voltage:	230V(195-253VAC) or 115V(96-125VAC) 24V DC (20-32V)
Power consumption:	50W at 24V, 70W at 230V or 115V
Alarm relay:	Change-over contact, max. 24V 300 mA
NMEA port:	9 pin D-Sub. 2 Inputs, 2 Outputs.
Operating temperature:	-15- +55 degree C according to IEC60945 To increase serviceability and life-time, we suggest the working temperature to be held at 0 - +40 degrees C.
Storage temperature:	-20 - +70 degree C
Humidity:	10 - 90% relative, no condensation.
Protection	IP 23

Junction Box

Operating temperature	-15 - 55 degree C IEC60945
Storage temperature:	-20 - 70 degree C
Protection:	IP33

Transducer (sensor)

Operating temperature	-15 - 55 degree C IEC60945
Storage temperature:	-20 - 70 degree C
Protection, Transducer:	submerged, 6 bar

7. TROUBLE SHOOTING

Symptom	Cause	Remedy
BASIC SYSTEM INTEGRITY		
No picture on LCD screen	<ul style="list-style-type: none"> No AC or DC power to the system System is in Standby mode Too low screen contrast Defective LCD module Voltage(s) out of range. 	<ul style="list-style-type: none"> Check switches and fuses on the Terminal Board inside the DL850 cabinet. Press any button on the panel. Increase contrast settings or replace Keyboard PCB. Replace LCD module Replace Terminal PCB
Picture is difficult to read	<ul style="list-style-type: none"> Backlight is too weak. 	<ul style="list-style-type: none"> Increase backlight settings.
Display Back light malfunctions. Display picture is visible	<ul style="list-style-type: none"> Error during initialisation. Defective backlight tubes Defective backlight power inverter. 	<ul style="list-style-type: none"> Turn off power and wait for 5 sec. before restart. Replace backlight tubes. Replace Inverter PCB.
Rotary Encoder malfunctions	<ul style="list-style-type: none"> Defective Encoder or interface SW problem 	<ul style="list-style-type: none"> Replace Keyboard PCB. Recycle power.
Panel buttons malfunctions	<ul style="list-style-type: none"> Defective buttons or interface One button stuck SW problem 	<ul style="list-style-type: none"> Replace Keyboard PCB or I/O PCB. Check key switches or replace Keyboard PCB. Recycle power
Loose user setup and calibration data	<ul style="list-style-type: none"> Battery backup not enabled. Battery empty 	<ul style="list-style-type: none"> See chapter for Jumper JP200 instructions. Replace battery or I/O board.
Ambient t in Status screen shows Too High.	<ul style="list-style-type: none"> Obstructed Air flow. Defective Fan 	<ul style="list-style-type: none"> Check installations for obstructions of vent holes. Replace fan.
Wrong Main Voltages, (acceptable Range) +5V CPU: (4.7V - 5.3 V) +5V IO: (4.7V - 5.3 V) +12V CPU: (11.3V - 12.7 V) +12V IO: (11.3V - 12.7 V)	<ul style="list-style-type: none"> Defective power supply. CPU or I/O PCB problem. Terminal PCB problem. CPU problem. 	<ul style="list-style-type: none"> Replace terminal PCB. Replace CPU or I/O PCB. Replace terminal PCB. Replace CPU.

Symptom	Cause	Remedy
INSTALLATION PROBLEMS		
Status screen shows Link: No sensor data. In Junction Box. LD203 not active.	<ul style="list-style-type: none"> • Junction box power is off • Incorrect supply voltage. 	<ul style="list-style-type: none"> • Switch on the power of the transceiver unit or check fuses. • Check supply voltage.
Status screen shows Link: No sensor data. In Junction Box: LD203 is active LD204 not active LD100 not active	<ul style="list-style-type: none"> • No power to sensor • Bad connection of the sensor cable • Defective sensor 	<ul style="list-style-type: none"> • Check voltage terminal 5 and 6 on J102. Should be 24V. • Check if the sensor is connected on the Junction box terminal according to colour diagram. • Test/replace sensor.
Status screen shows Link: No sensor data. In Junction Box: LD203 is active LD204 is flashing at app. 2Hz LD100 not active	<ul style="list-style-type: none"> • No serial communication with sensor. • Damaged cable/sensor 	<ul style="list-style-type: none"> • Check connection and polarity of the serial lines.. • Test/replace cable/sensor.
Status screen shows Link: No sensor data. In Junction Box: LD203 is active LD204 is flashing at app. 2Hz LD100 is flickering	<ul style="list-style-type: none"> • No serial communication between Junction Box and Operator unit. • Damaged communication cable. 	<ul style="list-style-type: none"> • Check connection and polarity of the serial lines.. • Test / replace cable.
INTERFACE PROBLEMS		
NMEA input signals are not listed in the NMEA Input screen.	<ul style="list-style-type: none"> • Wrong polarity of input signals. 	<ul style="list-style-type: none"> • Swap NMEA0183 input lines.
NMEA input signals are listed in the NMEA Input screen, but not accepted by the EML..	<ul style="list-style-type: none"> • Error during initialisation • Irregular Message Mnemonic 	<ul style="list-style-type: none"> • Cycle power of operator unit after NMEA Connection is established. • Check remote (talker) setup.
NMEA output signals are not accepted by the remote system	<ul style="list-style-type: none"> • Remote (Listener) setup. 	<ul style="list-style-type: none"> • Verify correct remote (Listener) setup.
Analogue output malfunctions	<ul style="list-style-type: none"> • Incorrect Range Settings 	<ul style="list-style-type: none"> • Verify upper and lower limits in status screen.
Pulse output malfunctions	<ul style="list-style-type: none"> • Incorrect Pulse Frequency settings 	<ul style="list-style-type: none"> • Verify Pulse settings in Status screen.
Alarm output do not work.	<ul style="list-style-type: none"> • Incorrect terminal • Defective output 	<ul style="list-style-type: none"> • Check use of ALNC and ALNO terminals. • Replace Terminal PCB
BASIC FUNCTIONALITY		
Constantly wrong speeds or no speed.	<ul style="list-style-type: none"> • Wrong calibration • Damaged sensor 	<ul style="list-style-type: none"> • Check calibration/recalibrate. • Replace sensor

TYPICAL STATUS SCREEN CONTENTS.

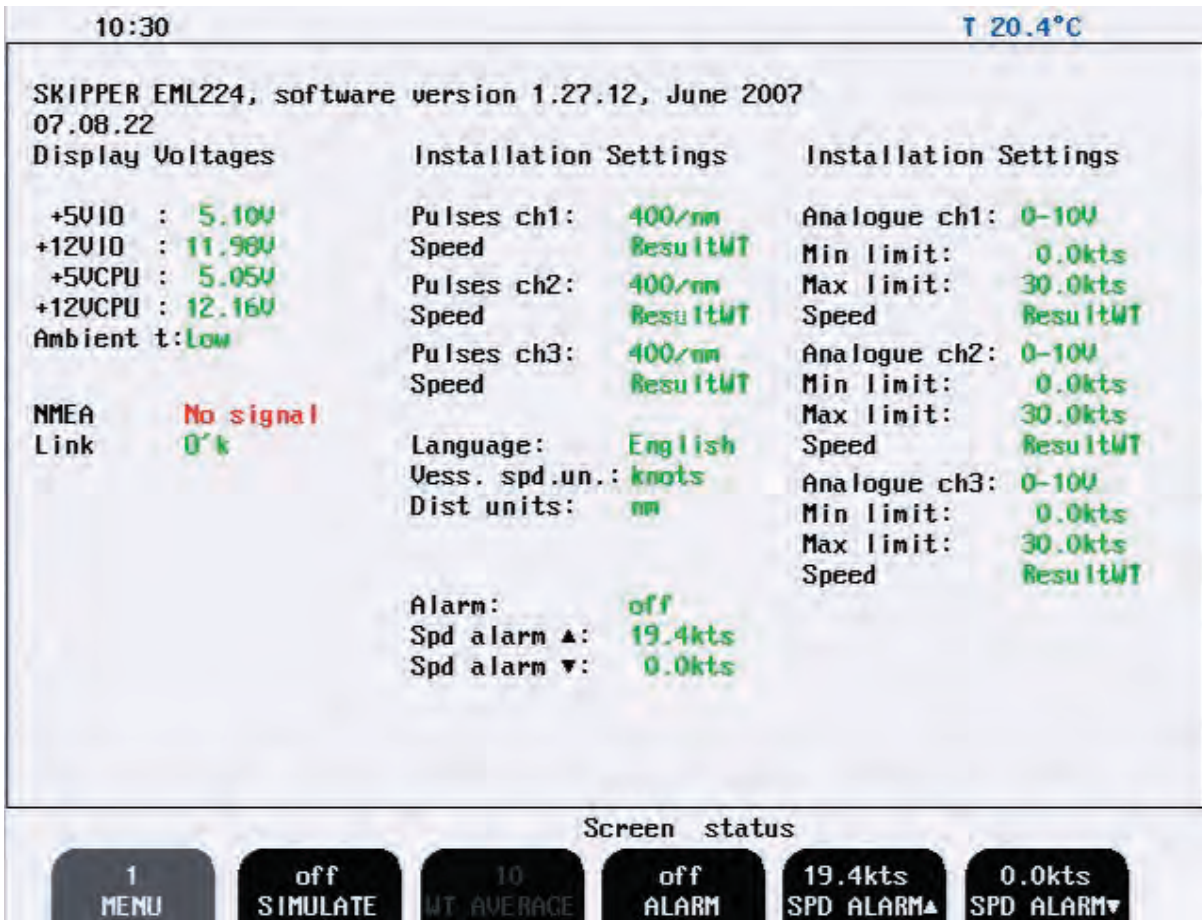

Fig. 7.1 Typical contents of status screen

The Status Screen contain information that will facilitate analysis and correction of several problems. Information from the Status Screen should be sent by fax with any report about functional disturbances. This will greatly facilitate remote failure analysis.

If it is possible to cycle through the screens and observe this information, several assumptions may be made regarding operation of the EML224 System. Although some of the subsystems necessary for this basic system operation may still suffer from minor or intermittent operation disorders, the fact that it is possible to select and observe this screen, indicate correct operation of the following EML224 Subsystems:

1. The Computer is operating.
2. The Keyboard interface Board with Backlight and LCD power supplies is working.
3. The Keyboard Interface Part of the I/O Board is working.
4. The Power Supplies on the terminal board are basically working.

The other information on the Status screen is a collection of information which may be observed and manipulated with the various screen softkey selections. As a reference, it will often be more convenient to observe the various settings together on this screen than to cycle from screen to screen to check on the softkey texts.

8. SERVICE

All service requests should be made to the local SKIPPER representative.

Adjustments and repairs should only be performed by qualified service engineers, and unqualified repair attempts will void the warranty.

9. APPENDIX

MISCELLANEOUS INSTALLATION DRAWINGS.

- System Overview
- Operator Unit Connection
- Sensor Connection
- Operator Unit Dimensions and mounting
- Junction Box Dimensions and mounting

RevNo	Revision note	Date	Signature	Checked
01	Special Cable info	28-03-01	VF	THA

Display / Operatot Unit

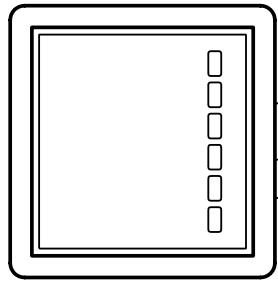

230/115 VAC (Max. 2 x 2.5 sq.mm.) Screened.
 24 VDC (Max. 2 x 2.5 sq.mm.) Screened.
 Yard Supply.

SCREENED CABLE:
 Minimum 2 twisted Pairs, 0.5sq.mm.
 with individual screens. Max length 400m
 Yard Supply.

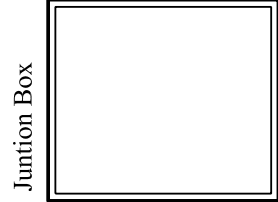

Juntion Box

For details,
 refer to connection
 diagrams and outline
 dimensions drawings

230/115 VAC (Max. 2 x 2.5 sq.mm.) Screened.
 24 VDC (Max. 2 x 2.5 sq.mm.) Screened.
 Yard Supply.

Transducer (sensor) Cable 30 meters : Diam. 10 mm
 8 wire cable, color label Supplied by SKIPPER

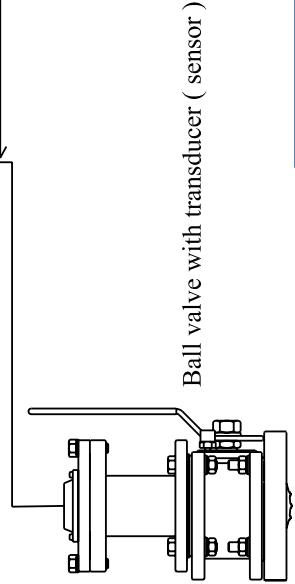

Ball valve with transducer (sensor)

Itemref	Quantity	Title/Name, designation, material, dimension etc	Article No./Reference
Designed by	Checked by	Approved by - date	Date
Arne Mairre	VF	VF-2005.03.14	14.03.01
		File name	Scale
		Overview	
Skipper Electronics A/S		EML224 Overview	
		Edition	Sheet
		0	1/1

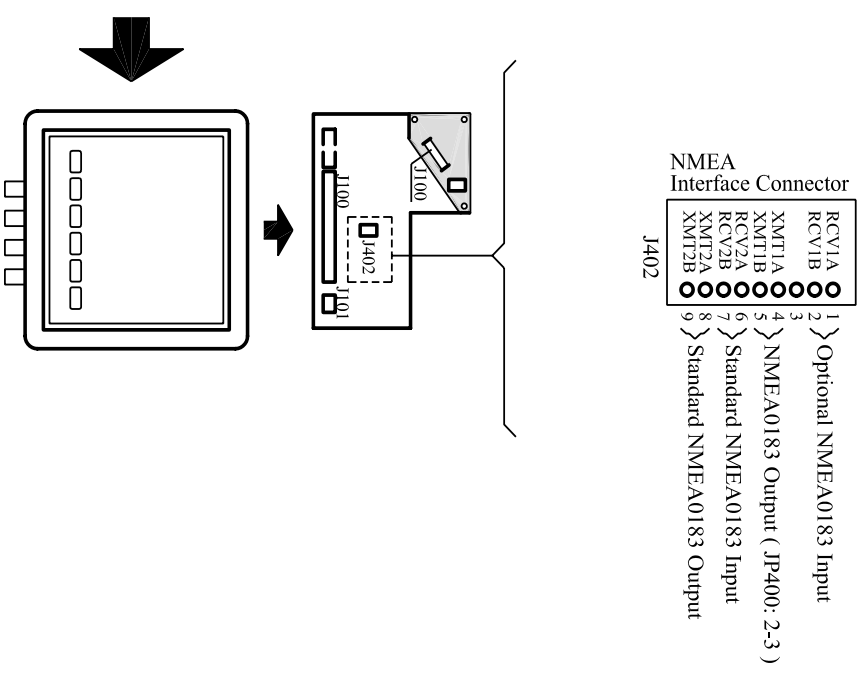
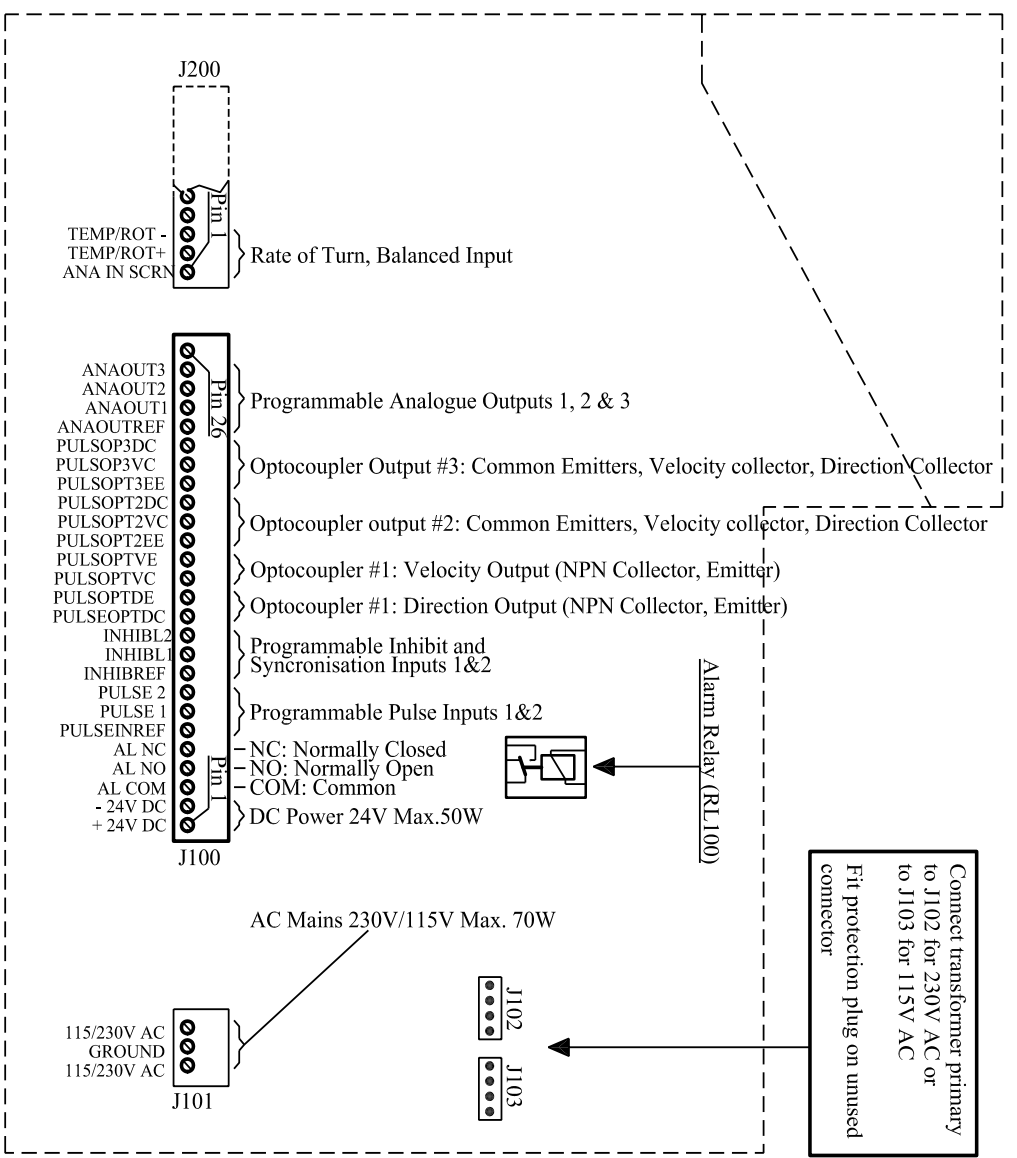

Connections in Display / Operator Unit Combo Terminal PCB Version C

Itemref	Quantity	Title/Name, designation, material, dimension etc	Article No./Reference
Designed by Arne Maire	Checked by VF	Approved by - date VF-2005.03.14	Date 14.03.01
Skipper Electronics A/S		File name Oper-Unit-Ex1C	Scale
DL8-B-002		Edition 0	Sheet 1/1

DL8-B-002 Operator Unit Connection

Display/Operator Unit

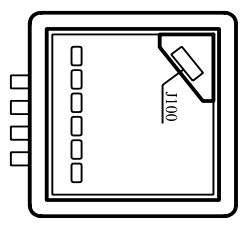

Junction Box (with EML224 Sensor Power Ver. A or B)

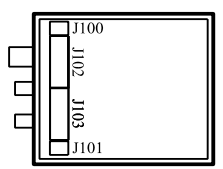

Sensor Power Ver. B * Sensor Power Ver. A *

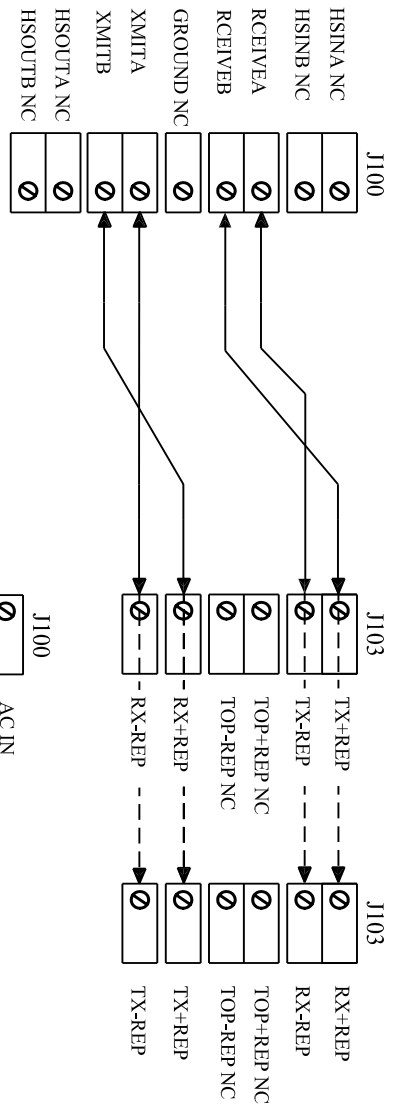

RS422 Terminal Adaptor Ver. A13

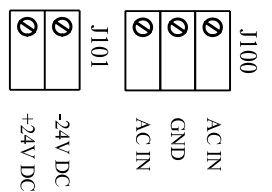

Junction Box (with EML224 Sensor Power Ver. A or B)

* see marking on sensor power pcb

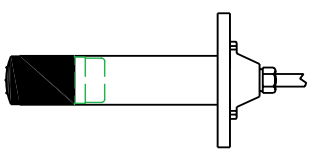
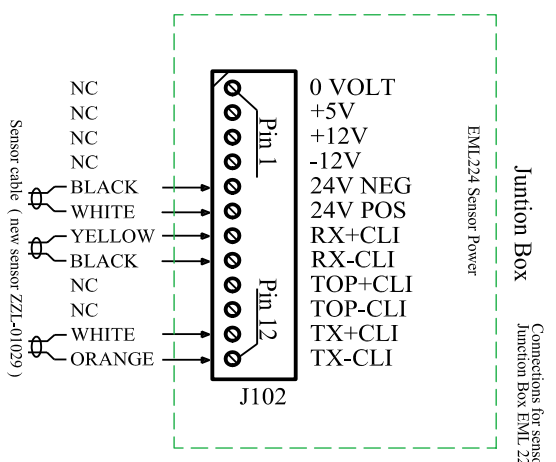

Itemref	Quantity	Title/Name, designation, material, dimension etc	Article No./Reference
Designed by Arne Maire	Checked by SG	Approved by - date VF-2005.03.30	Date 2005.03.30
File name InterconnWS		Scale	

Skipper Electronics A/S

New Sensor ZZL-01029

EML-B-003

Edition
0

Sheet
1/1

1	2	3	4
RevNo	Revision note	Date	Signature
			Checked

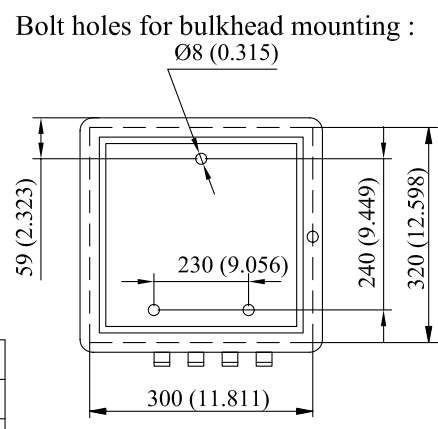
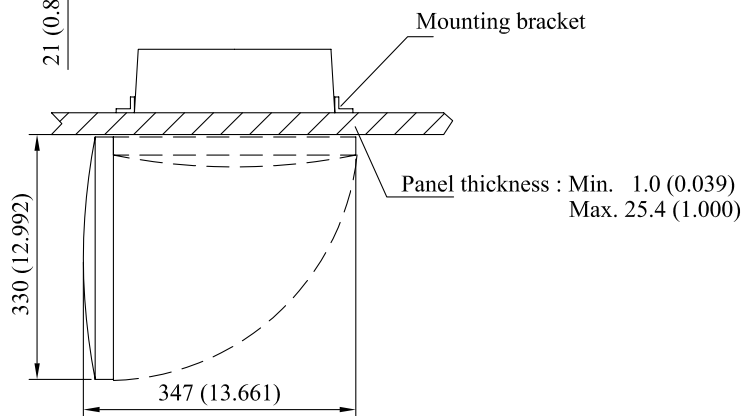
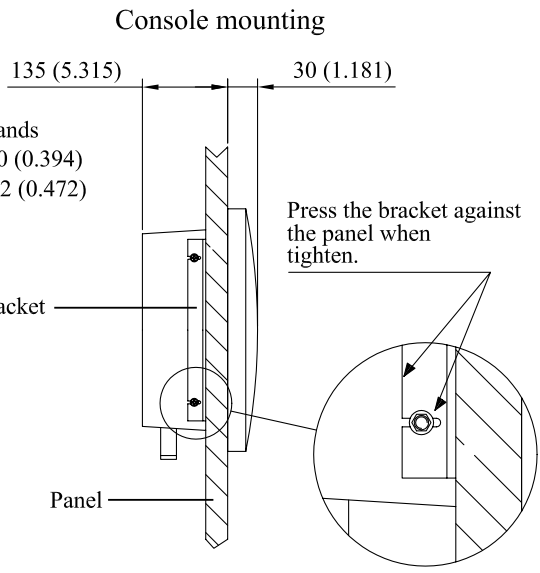
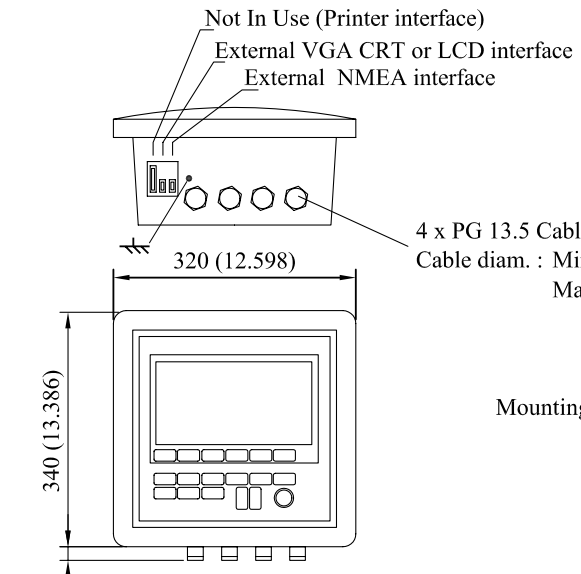

Panel Cut Out for console mounting:
300 wide x 320 high
(11.811) x (12.598)

Supply voltage	115/230VAC or/and 24VDC
Current consumption	115VAC/0.6A;230VAC/0.3A;24VDC/2A
Power consumption	Max. : 70W/AC, 50W/DC
Operating temperature range	-15° C+55° C
Storage temperature range	-20° C+70° C
Protection code	IP23
Weight	10 Kg
Distance from magnetic compass : Standard type : 0,5m	
Steering type : 0,25	

Itemref	Quantity	Title/Name, designation, material, dimension etc			Article No./Reference
Designed by VF	Checked by TW	Approved by - date VF-2002/07/23	File name TB3007EML	Date 2005/02/14	Scale
Skipper Electronics			Operator Unit EML224		
			TB3007EML	Edition 1	Sheet 1/1

1	2	3	4
RevNo	Revision note	Date	Signature
			Checked

Junction Box EML 224

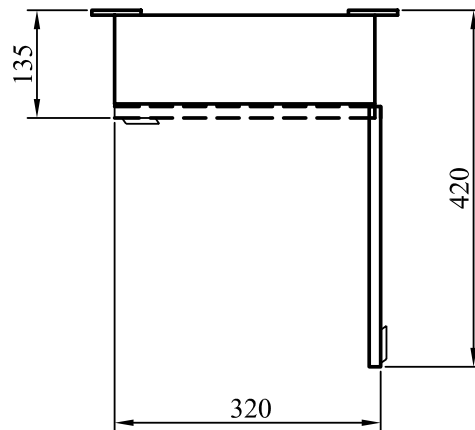
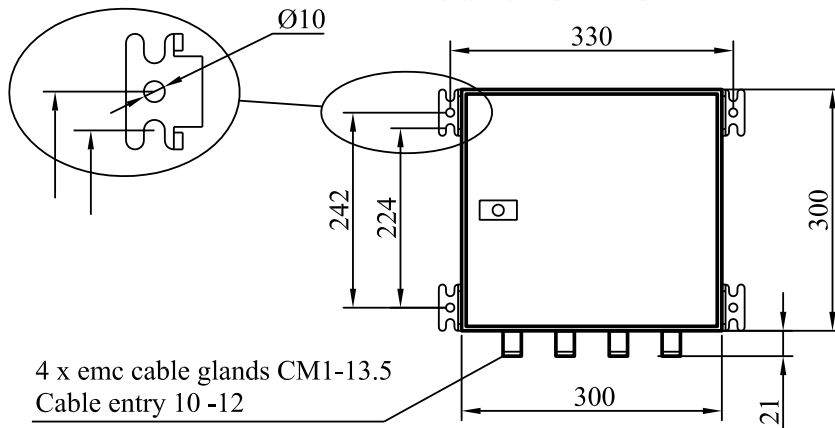

Outline Dimensions for Junction Box

Supply voltage	115/230VAC or/and 24VDC
Current consumption	115VAC/0.3A;230VAC/0.15A;24VDC/1,5A
Power consumption	Max. 35W
Operating temperature range	-15° C+55° C
Storage temperature range	-20° C+70° C
Protection code	IP33
Weight	6 Kg
Distance from magnetic compass : Standard type : 1,0m	
Steering type : 0,7m	

Itemref	Quantity	Title/Name, designation, material, dimension etc			Article No./Reference	
Designed by AM	Checked by VF	Approved by - date VF 2002/07/30	File name TB3008EML	Date 2005/02/14	Scale	
Skipper Electronics			Junction Box EML 224			
			TB3008 EML224	Edition 1	Sheet 1/1	